



Find Your Energy Freedom™

Renogy

PGH1 Series

Battery Power Inverter

12V | 1000W/2000W/3000W

VERSION A3



USER MANUAL

Applicability

The user manual applies to the following products:

- Renogy PGH1 12V 1000W Battery Power Inverter (PGH1-10111S)
- Renogy PGH1 12V 2000W Battery Power Inverter (PGH1-20111S)
- Renogy PGH1 12V 3000W Battery Power Inverter (PGH1-30111S)

Disclaimer

- Renogy ensures the accuracy, sufficiency, and the applicability of information in the user manual at the time of printing due to continual product improvements that may occur.
- Renogy assumes no responsibility or liability for personal and property losses, whether directly and indirectly, caused by the user's failure to install and use the product in compliance with the user manual.
- Renogy is not responsible or liable for failures, damages, or injuries resulting from repair attempted by unqualified personnel, improper installation and operation.
- The illustrations in the user manual are for demonstration purposes only. Details may appear slightly different depending on product revision and market region.
- Renogy reserves the right to change the information in the user manual without notice. For the latest user manual, visit [renogy.com](https://www.renogy.com).

Copyright

Renogy PGH1 Series Battery Power Inverter User Manual © 2022 Renogy. All rights reserved. All information in the user manual is subject to copyright and other intellectual property rights of Renogy and its licensors. The user manual may not be modified, reproduced, or copied, in whole or in part, without the prior written permissions of Renogy and its licensors.

Trademark

The following are registered trademarks of Renogy:

RENOGY	RENOGY
--------	---------------

The registered trademarks in the user manual are the property of Renogy. The unauthorized use of the trademarks is strictly prohibited.

Date and Revision

October 2022, Revision A3

Table of Contents

Important Safety Information	01
Symbols Used	01
General Safety Information	01
Overview	03
Introduction	03
Key Features	03
Pure Sine Wave	03
Package Contents	04
Included Components	04
Optional Components	04
Product Overview	05
Identification of Parts (AC Side)	05
Identification of Parts (DC Side)	06
Installation	07
Location Recommendations	07
Sizing your Battery Bank	08
Wiring	09
Grounding	09
DC Wiring	09
AC Wiring	11
Fusing	13
Operation	14
AC Side Operation	14
LED Overview	14
Wired Remote	15
DIP Switches	15
Troubleshooting	16
Technical Specifications	18
Dimensions	20

1000W Inverter (PGH1-10111S)	20
2000W Inverter (PGH1-20111S)	20
3000W Inverter (PGH1-30111S)	21
Maintenance	22
Inspection	22
Cleaning	22
Storage	22
Emergency Responses	23
Fire	23
Flooding	23
Smell	23
Noise	23
Technical Support	24

Important Safety Information

Symbols Used

General Safety Information

The user manual provides important installation, operation, and maintenance instructions for Renogy PGH1 Series Battery Power Inverter (hereinafter referred to as inverter). Read the user manual carefully before installation and operation and save it for future reference. Failure to observe the instructions or precautions in the user manual can result in electrical shock, serious injury, or death, or can damage the inverter, potentially rendering it inoperable. The installation and service of the inverter might require knowledge of electricity and is recommended to be carried out by qualified personnel.

Symbols Used

The following symbols are used throughout the user manual to highlight important information:



WARNING

Indicates a potentially dangerous condition which could result in injury or death.



CAUTION

Indicates a critical procedure for safe and proper installation and operation.



NOTE

Indicates an important step or tip for optimal performance.



INFO

Indicates that more information is available in other documents relating to the subject.

General Safety Information



WARNING

- Inspect the inverter for any visible damage including cracks, dents, deformation, and other visible abnormalities before installation.
- Do not puncture, drop, crush, penetrate, shake, strike, or step on the inverter.
- Do not open, dismantle, repair, tamper with, or modify the components of the inverter.
- Install the inverter on a vertical surface indoors protected from direct sunlight, high temperature, and water. Make sure there is good ventilation.
- Make sure all connections going into and from the inverter are tight. There may be sparks when making connections, therefore, make sure there are not flammable materials or gases near installation.
- Keep the inverter away from heating equipment.
- Do not insert foreign objects into the inverter.
- Do not install the inverter near flammable fumes or gases.
- Keep the inverter out of the reach of children.
- Wear proper protective equipment and use insulated tools during installation and operation. Do not wear metal jewelry, such as necklaces and watches.

Important Safety Information

Symbols Used

General Safety Information

- Do not touch the connector contacts while the inverter is in operation.
- Disconnect all connectors from the inverter before maintenance or cleaning.
- Risk of electric shock! Be careful when touching bare terminals of the inverter as they may retain high lethal voltages even after power is removed.
- Do not dispose of the inverter as household waste. Comply with local, state, and federal laws and regulations and use recycling channels as required.
- In the event of fire, use fire extinguishers suitable for electrical equipment.
- If the inverter is installed improperly on a boat, it may cause damage to the corrosive agents of the boat. Please have the inverter installed by a qualified electrician.



CAUTION

- Do not expose the inverter to flammable or harsh chemicals or vapors.
- Ensure that there is no water source including downspouts, sprinklers, or faucets above or near the inverter.
- Ensure that the battery bank is properly connected before installation.
- Check the installation environment of the inverter regularly and keep it clean to prevent the ventilation holes from being blocked by debris or dust.

■ Inverter Safety

- The inverters are suitable for 12V Battery Banks ONLY.
- ALWAYS make sure the inverter is in OFF position and disconnect all AC and DC connecting when working on any circuit associated with the inverter.
- NEVER connect the AC output of the inverter directly to an Electrical Breaker Panel/Load Centre which is also fed from the utility power/generator.
- When connecting battery terminals, ensure the polarity of the battery connections is correct. Incorrect polarity may cause permanent damage to the inverter.

■ Battery Safety

- Do NOT let the positive (+) and negative (-) terminals of the battery touch each other.
- Use Sealed Lead Acid, AGM, Flooded, Gel, or Lithium batteries which must be deep cycle.
- Explosive battery gases may be present while charging. Be certain there is enough ventilation to release the gases.
- Be careful when working with large lead acid batteries. Wear eye protection and have fresh water available in case there is contact with the battery acid.
- Over-charging and excessive gas precipitation may damage the battery plates and activate material shedding on them. Too high of an equalizing charge or too long of one may cause damage. Please carefully review the specific requirements of the battery used in the system.

Overview

Introduction

Key Features

Pure Sine Wave

Introduction

The Renogy PGH1 Series Battery Power Inverter transforms the DC power stored in batteries into standard household AC power for consumer electronic needs. It features an ECO power-saving mode in order to conserve your system's energy and even has a switch to change the frequency between 50Hz / 60Hz. As a pure sine wave inverter, it is capable of producing cleaner, smoother, quieter, and more reliable electricity to operate fans, lights, and other electronics without interference.

Key Features

- Robust and sleek design
- Pure sine wave output (THD<3%)
- Excellent Surge Rating: 2x the Power Rating
- Optimized for 12VDC system voltage
- Easy-to-read LED indicator display
- Multiple protection features (LVD, HVD, AC Overload and Over Temperature)
- Clean power for safe operation of sensitive electronics
- Power Saving Mode to conserve energy

Pure Sine Wave

The Renogy PGH1 Series Battery Power Inverter output a pure sine wave similar to the waveform of the grid power. In a pure sine wave, the voltage rises and falls in a smooth fashion with very low harmonic distortion and cleaner utility-like power.

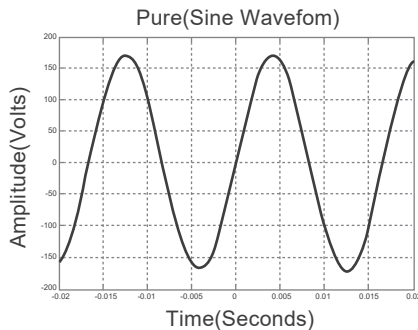

This gives users stable enough power to operate tools, fans, lights, computers, and other electronics without any interference. Pure sine wave inverters are in many cases more efficient, allowing users to use less energy and allow for more device capability. The main advantage to pure sine wave inverters is that they are used to operate sensitive electronic devices that require a high quality waveform with little harmonic distortion. Almost any electronic device could be powered using a pure sine wave inverter.

Package Contents

Included Components

Optional Components

Included Components

The inverter will include a wired remote controller that can power the inverter ON or OFF. In addition, the 1000W and 2000W models will include inverter cables.

Inverter Model	Gauge
1000W Inverter (PGH1-10111S)	4 AWG
2000W Inverter (PGH1-20111S)	4 AWG * 2
3000W Inverter (PGH1-30111S)	Cables not included. 4/0 Recommended



Wired Remote Control

The Wired Remote Control for the inverter gives users the opportunity to power on/off the inverter from a distance. Giving you approximately 16.4ft of distance, simply connect the cable to the REMOTE port on the PGH inverter. Make sure the inverter switch is flipped to REM and the wired remote power button is unpressed. When connected, press the wired remote's power button to turn on the inverter.

Optional Components



Monitoring Screen (Model: RMS-PGH)

The RMS-PGH is a high precision meter designed for the PGH1 Power Saving Inverter Series. Utilize the 2-key input to easily navigate through your system information as well as identify any error codes. You can also use the main push button to power your inverter on/off at your convenience. The RMS-PGH is the perfect monitor companion to optimize any solar-inverter system!

Product Overview

Identification of Parts (AC Side)

Identification of Parts (DC Side)

Identification of Parts (AC Side)

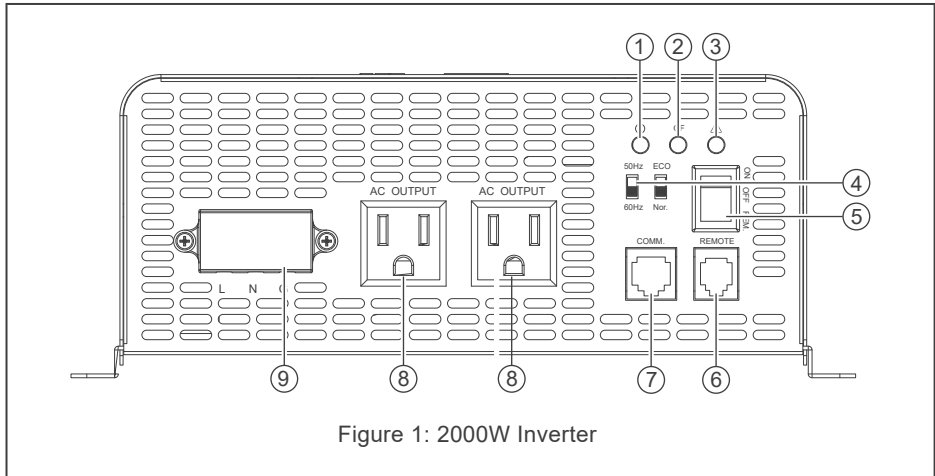

Figure 1: 2000W Inverter

No.	Part
1	Power LED (Green): Solid Green indicates normal power on operation. Flashing Green indicates inverter is powered in ECO power saving mode and is pulsing.
2	GF LED (Yellow): Indicates an interruption in the circuit. Shut down the inverter to clear or review AC wiring. The inverter does not have Neutral and Ground bonded. Refer to Troubleshooting.
3	Fault LED (Red) + Alarm: Solid Red light indicates a system fault due to either overheating, overload, undervoltage, or over-voltage. Alarm sounding is typical for a low battery voltage. Refer to Troubleshooting.
4	DIP Switches (Frequency/Power Saver): Adjust the frequency or ECO power saver mode.
5	ON/OFF/REM Power Button: Main power button that can switch between ON, Off, or be in Remote control mode.
6	Remote Port: Connect the included wired remote onto this port.
7	Communication Port (RS485): Optional port for connecting the BT-2 Module (Model: RCM-BT2) or Monitoring Screen (Model: RMS-PGH). Requires separate purchase.
8	AC Outlets: Directly plug in AC appliances. Utilize up to 8.3Amps (1000W) or up to 15amps (2000W/3000W).
9	AC Terminal Block (Covered): Use the terminal block to utilize the full wattage in 110V AC 50Hz / 60Hz for the 2000W / 3000W models. 1000W model can use full wattage using the AC outlets.

Product Overview

Identification of Parts (AC Side)

Identification of Parts (DC Side)

Identification of Parts (DC Side)

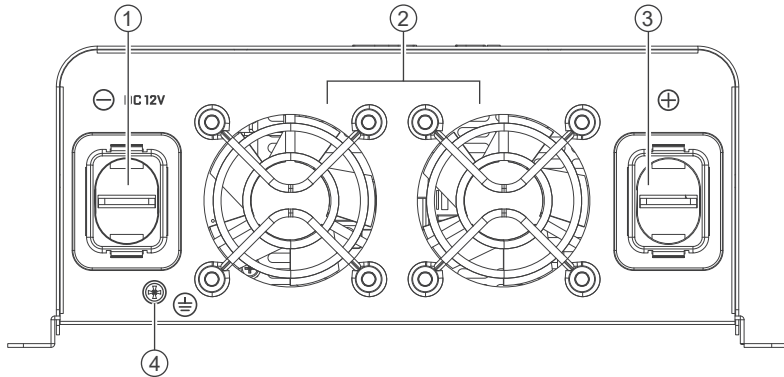

Figure 1: 2000W Inverter

No.	Part
1	12VDC M8 Negative Battery Terminal: Negative 12V DC is written above the terminal.
2	Ventilation Fans: Automatic fans that dissipate heat inside the inverter. They that are temperature controlled.
3	12VDC M8 Positive Battery Terminal: Positive 12V DC is written above the terminal.
4	M4 Grounding Lug: Connect to grounding point which will vary depending on install.



WARNING

- Make sure inverter is in the off position before connecting anything.



CAUTION

- Do not over tighten the terminals. This could potentially damage the inverter.

Location Recommendations



WARNING

- Never install the inverter in a sealed enclosure with flooded batteries. Gas can accumulate and there is a risk of explosion.

Ensure installation follows the following guidelines:

- 1. Cool, dry, well-ventilated area:** Heat is the worst enemy for electronic equipment. Inverters must be in an area where the fans are not blocked or where they are not hit directly by the sun. They should be in an area free of any kind of moisture and allow for clearance of at least 10" around the inverter to provide for adequate ventilation.
- 2. Protection against fire hazard:** the inverter should be away from any flammable material, liquids, or any other combustible material. The inverter can spark and the consequences could be severe.
- 3. Close proximity to battery bank:** prevent excessive voltage drop by keeping the inverter close to the battery bank and having a properly sized wire going from the battery bank to the inverter.
- 4. Limiting electromagnetic interference (EMI):** ensure the inverter is firmly grounded to a building, vehicle, or earth grounded. Keep the inverter away from EMI receptors such as TVs, radios, and other audio/visual electronics to prevent damage / interference to the equipment.
- 5. Secure mounting:** The inverter should be standalone or mounted by using the outlying terminals with M6 or M8 screws on the inverter.



WARNING

- The inverter should be mounted to a solid horizontal base. Vertical installations need to ensure clearance of fans for proper cooling. Never mount the inverter upside down due to lack of heat dissipation.

Sizing your Battery Bank

Battery types and capacity relate to overall inverter performance. To size a battery bank, you need to identify the loads that you will be utilizing, as well as an estimate (hours/day) you will be using the load. The inverter is only compatible with 12V battery banks and oversizing should be considered due to efficiency losses.

1. **Determine your Watts (Amps * Volts):** every electronic will have a sticker or plate identifying the watts directly (W) or will show you the voltage value (V) as well as amperage (A) which need to be multiplied to get Watts. The formula is below:

$$\text{Watts (W)} = \text{Volts (V)} * \text{Amps (A)}$$

$$\text{Fan Watts} = 120\text{V} * 0.4\text{A} = 48\text{Watts}$$

2. **Estimate Load Run:** Time in Watt-Hours (Wh)—Estimate how many hours per day you will be using the load and multiply this by your Watts per load.

$$\text{Fan Watts} * 12 \text{ hours} = \text{Watt-Hour (Wh)}$$

$$46\text{W} * 12\text{h} = 576\text{Wh}$$

3. **Determine Battery Capacity in Amp-Hour (Ah):** Divide your Load Run Watt-Hour result by the battery voltage. This inverter is 12V, so we will use this as the reference:

$$\text{Load Run-Time (Wh)} / \text{Battery Voltage (V)} = \text{Amp-Hour (Ah)}$$

$$576\text{Wh} / 12\text{V} = 48 \text{ Ah}$$

4. **Oversize the Battery:** The calculated Amp-Hour value represents the minimum size battery capacity to run your load for your intended time. Note that this assumes 100% use of a battery, which is not recommended. Assuming 50% depth of discharge (DoD), you want to divide by this value and then multiply by a factor of 1.25 to account for some efficiency losses.

NOTE

- You will need a battery charging source as this is a non-charging inverter and will only work to deplete the battery.

$$(\text{Amp-Hour} / \text{DoD}\%) * \text{Efficiency Losses} = \text{Recommended Amp-Hour}$$

$$(48\text{Ah} / 50\% \text{ DoD}) * 1.2 = \text{Approx. } 115\text{Ah}$$

A 115Ah battery bank, or close, will be able to support a 12-hour run time while also prolonging battery life for the best system size possible.

NOTE

- This is an example and actual quantities vary by battery capacity and rates of discharge.

Grounding

If available, the chassis ground lug should be connected to a ground point such as a vehicle chassis or boat grounding system. In fixed locations, connect the ground lug to earth ground. The connections to ground must be tight and against bare metal. Whether using the inverter in a mobile application, such as an RV, or in a building, grounding is highly recommended. The recommended wire size for grounding is 14AWG (1000W), 12AWG (2000W), and 10 AWG (3000W) insulated copper strand wire.

The neutral (common) is not bonded to the chassis ground. Therefore, when chassis is connected to ground, the neutral conductor is not grounded. At no point should the chassis ground and the neutral conductor of the inverter be bonded. Bonding the chassis ground and the neutral conductor of the inverter or connecting the inverter to household AC distribution wiring will damage the inverter and void the warranty. For more information regarding grounding, users and/or installers must consult with the Local and National Electric Codes (NEC) for more specific grounding regulations and suggestions as they can change per scenario.



WARNING

- At no point should the chassis ground and the neutral conductor of the inverter be bonded. Bonding the chassis ground and the neutral conductor of the inverter or connecting the inverter to household or recreational AC distribution wiring will damage the inverter and void the warranty.



CAUTION

- Do not over-tighten the M4 Ground Screw. The recommended torque is 1.5~2.0N·m / 13~18.2 lbf-in.

DC Wiring



WARNING

- The Renogy Pure Sine Wave Inverters are suitable for 12V battery bank systems ONLY. Not following the minimum DC requirement will cause irreversible damage to the inverter.



CAUTION

- Be careful of the positive and negative poles. Reversing the poles might cause permanent damage to the inverter. It will surely blow the internal fuse.



NOTE

- Damage to the Renogy inverters due to reverse polarity is NOT covered by warranty. The input terminals of the inverters have large capacitors connected to them. Once a positive and negative wire are connected to the terminals, it will complete the circuit, and commence drawing a heavy current momentarily. As a result, there may be a sparking occurring even if the inverter is in the off position. To minimize sparking, it is recommended that the user have the appropriate size wire feeding into the inverters and/ or install an external fuse leading into the inverter.

Wiring

Grounding

DC Wiring

AC Wiring

Fusing

- Do not over-tighten the M8 DC Terminals. The recommended torque is 12 ~ 16N-m / 105.9 ~ 141.5 lbf-in.

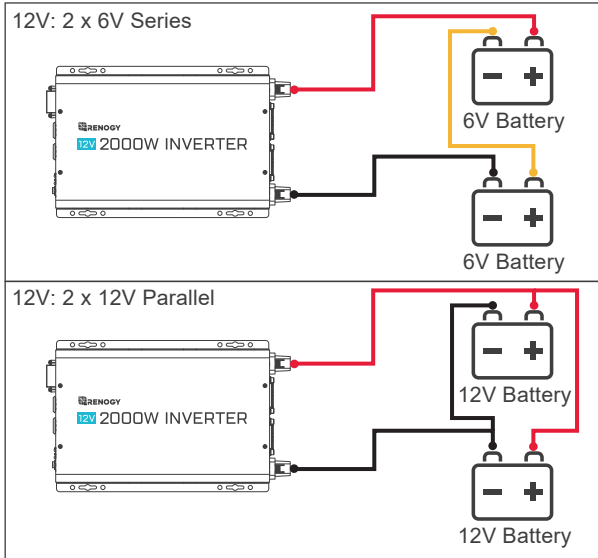

1. Make sure your battery bank is rated for 12V. Batteries that are 6V may be put in series to create a 12V battery bank. 12V batteries may be connected in parallel prior to connecting to the inverter DC terminals. When joining batteries together, they must be the same chemistry, voltage, and are also recommended to be the same level prior to combining.

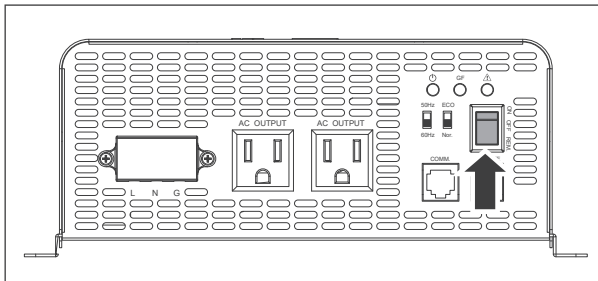

2. Flip inverter power to OFF position (on AC side).

Wiring

Grounding

DC Wiring

AC Wiring

Fusing

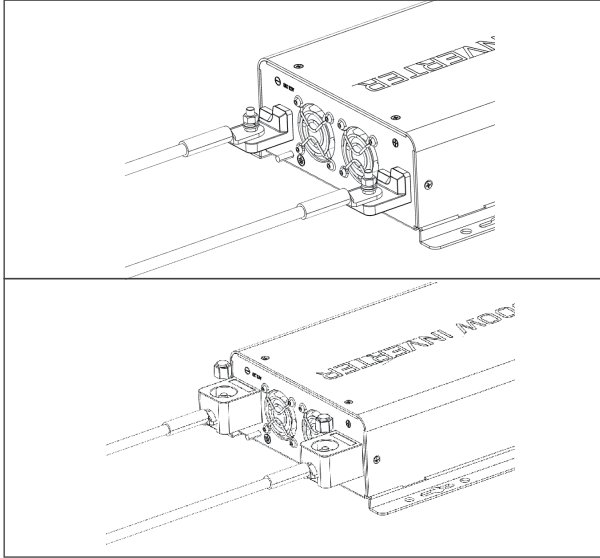

3. Remove Cap, then unscrew inverter terminals and connect battery connections. Then tighten.

AC Wiring

WARNING

- All AC Wiring should be approved by an electrician for RV or Marine applications. Do not connect the AC Output to a power source like a generator/shore power. Irreversible damage may occur to the inverter.

NOTE

- Do not over-tighten the screws in the AC Terminal Cover or Terminal Block. The recommended torque for the M3 terminal cover screws is $.64 \sim 1.0\text{N}\cdot\text{m}$ / $5.7 \sim 9.1 \text{ lbf}\cdot\text{in}$.
- The recommended torque for the M4 terminal block is Max $0.98\text{N}\cdot\text{m}$ / $8.7 \text{ lbf}\cdot\text{in}$.

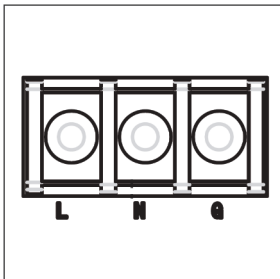

You can plug your AC loads directly into the receptacles on the inverter's AC Side. You can also hardwire (permanently connect) the AC output from the AC hardwire terminal through the AC knockout into a load sub-panel or additional AC outlets powered by the inverter. From left to right, the terminal block indicates: Live/Hot (L), Neutral (N), and Ground (G).

■ Typical Colors for AC Wiring

Live	Neutral	Ground
Red	White	Green
Black	Light Grey	Bare
Brown	-	-
Blue	-	-

■ Recommended Ground-Fault Circuit Interrupter (GFCI)

A ground-fault circuit interrupter, or GFCI, is a device that help protect people from electric shocks by de-energizing a circuit or portion of a circuit within an established period of time when a current to ground exceeds some predetermined value that is less than that required to operate the overcurrent device (circuit breaker or fuse) of the supply circuit. GFCIs are usually required in wet or damp locations.

While the inverter is equipped with a GFCI, it is recommended to install an external GFCI where you can manually test the circuit.

The following table lists GFCIs that meet the specifications and will function properly when they are connected to the AC Outlets of the inverter.

Tested GFCI Models	
Manufacturer	Model Number
Leviton	GFNT2
Hubbell	GFRST20
Hubbell	GF15WLA



WARNING

- Risk of electrical shock. Use only ground-fault circuit interrupters [receptacle(s) or circuit breaker(s)] compatible with your PGH1 inverter.



CAUTION

- GFCIs shall be installed in a recreational vehicle's wiring system to protect all branch circuits.

Wiring

Grounding

DC Wiring

AC Wiring

Fusing

Fusing

The following are recommended fuse minimums:

Model	Fuse Minimum	AWG Minimum
1000W Inverter (PGH1-10111S)	100A	4 AWG
2000W Inverter (PGH1-20111S)	200A	2 AWG
3000W Inverter (PGH1-30111S)	300A	4/0 AWG

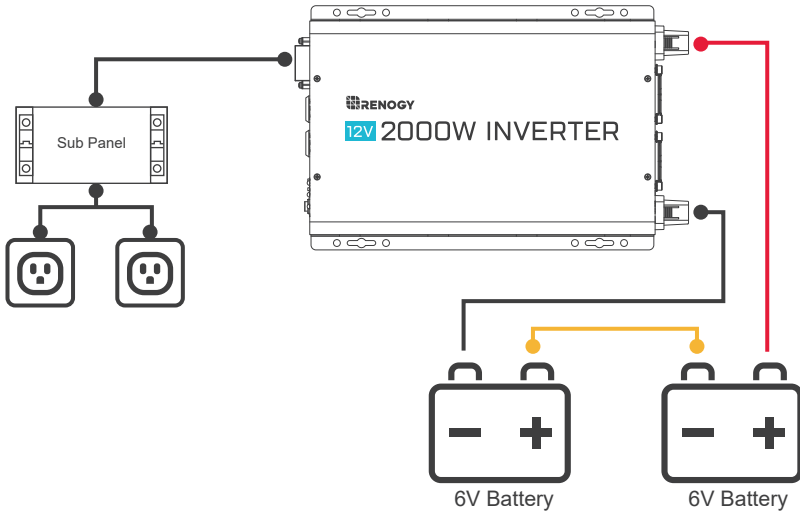

Operation

Assuming proper connection, the inverter is now ready for use. To operate using the AC Outlets:

AC Side Operation

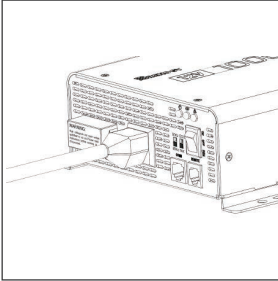

1. Connect electronic devices to electrical socket(s) on inverter. Flip inverter power to ON position (on AC side).
2. When finished, switch AC devices off FIRST, then turn off inverter switch.
3. Turn the device's power switch on to begin normal use.
4. To power down, turn off the device first then proceed to shut down the inverter.





CAUTION

- Avoid connecting powered on Devices before connecting to the inverter. Devices in the ON position may trigger an overload as they might have a high initial startup power when first connecting to the inverter.

LED Overview

The inverter has 3 LEDs that dictate different events: Power, Ground fault, and Fault.

LED	Behavior	Meaning
Power (Green) 	Solid	The inverter is powered on (normal mode).
	Slow Flash	Eco power saving mode. The inverter will pulse to detect any AC loads above 50W.
GF (Yellow) 	Solid	Ground fault detection of an unintentional electric path diverting current to ground.
Fault (Red) + Alarm 	Solid	Inverter Overheating Inverter Overload Inverter Undervoltage Inverter Overvoltage

Wired Remote

CAUTION

- The wired remote will only operate when REM mode is pressed on the inverter.

The wired remote control is an alternative way to power on or off your inverter from a distance. To operate:



1. Make sure the push button on the wired remote is not pressed.
2. Flip the inverter switch to REM mode.
3. Connect the remote wire to the REMOTE port on the inverter model.
4. To confirm success, press the power button to power on the inverter via remote.

DIP Switches

The DIP switches allow you to control the inverter's ac output frequency or power up in an ECO power saving mode. For DIP switch changes to take effect you must:

1. Shut down the inverter via power button or remote.
2. Make the desired dip switch change.
3. Power On the inverter via power button or remote.
4. DIP Switch changes have taken effect.

■ Frequency DIP Switch

You can change your AC output frequency between 50Hz or 60Hz depending on your location. By default, the USA uses 60Hz.

■ ECO Mode

ECO mode is a battery saver mode. When on, the inverter will search for a load by sending a pulse every 2~3 seconds to the AC outlets. The Power LED will also pulse. Loads that are 50Watts or less will not be powered on and the inverter will remain in this mode until 50W or greater is detected or until it is manually shutdown.

Power Mode	Power LED	AC Load \leq 50W	AC Load $>$ 50W
Normal	Solid	Power On	Power On
ECO	Pulsing	Idle	Power On

Troubleshooting

Indicator	Potential Issue	Troubleshoot
Fault LED Lit and Alarm Beeps	Battery Undervoltage Alarm	The battery is depleting faster than it is being charged. Lower the inverter load power or disconnect the load to let the battery charge up to 12.0V at least.
	Battery Overvoltage Alarm	The battery is at a higher than normal voltage, perhaps from being charged. Use a multi-meter to confirm the voltage and disconnect any chargers.
Fault LED Lit, Inverter shutdown, alarm on	Input Voltage has reached the low voltage disconnect and shut down the inverter	Disconnect any loads and use a charging source to charge the battery bank back up to an appropriate voltage of at least 12.0V.
	Input Voltage has reached the high voltage disconnect and shut down the inverter	Double check the charger is rated for the battery type. Use a multi-meter to check for the source of the high voltage and disconnect any chargers.
	Inverter High Temperature	Allow the inverter to cool down by disconnecting any loads or by physically moving the inverter to a cooler location. Check for adequate ventilation.
	Load Output exceeds inverter rating	Double check the appliance and make sure the watts (volts X amps) are within the specified rating of the inverter. In addition, make sure your batteries are fully charged as a low charged battery and a high load will also fault.
	Inverter experiencing a short circuit	Shut down the inverter, disconnect all connections and reconnect again.

Troubleshooting

Indicator	Potential Issue	Troubleshoot
Yellow GFCI Indicator Lit	Problem with the AC outlets	The GFCI equipment is sensitive and could trip when other GFCIs are present. Make sure there are none, or that they do not interfere in the same circuit. Keep your AC output connected directly to a load or extension cord and avoid complicated connections when utilizing the AC Outlet. Utilize the AC terminal block for making AC connections and minimize any GFCI error.
	GFCI issue with electrical panel	GFCI can trip when wiring up to an electrical panel. An electrical panel and/or the AC wiring can cause the GFCI to detect a discrepancy between line and neutral, as if there was a ground leak. Standard GFCIs tend to trip when other GFCI outlets are present. Utilize the AC terminal block as the alternative in your application. More complex solutions might require Double checking your AC output connection and verifying correct paths between the neutral, and ground and should be checked by a qualified electrician.

Technical Specifications

Model	1000W Inverter (PGH1-10111S)	2000W Inverter (PGH1-20111S)	3000W Inverter (PGH1-30111S)
Continuous Power	1000W	2000W	3000W
Input Voltage	12V DC		
Output Voltage	120V (±10%) AC		
Peak Surge	2000W	4000W	6000W
Efficiency	>90%		
Frequency	50Hz / 60Hz (adjustable)		
Total Harmonic Distortion	Linear Load: <3% Non-linear Load: <5%		
No Load Consumption	<1A	<2A	<3A
High Voltage Disconnect	16V (±0.3V) DC		
Battery Under-voltage Alarm	11V (±0.3V) DC		
Low Voltage Shutdown	10.5V (±0.3V) DC		
Normal Operating Voltage	11V ~ 15V DC		
Cooling	Thermally controlled fans		
AC Sockets	1	2	
Temperature Range	Operating Temperature: -4°F ~ 104°F / -20°C ~ 40°C		
	Storage Temperature: -40°F ~ 158°F / -40°C ~ 70°C		
Power Output Control	Inverter Power Switch, Remote		
Terminals (D-P x L)	AC Terminal Cover: M3-0.5 x 8 AC Terminal Block: M4-0.7 x 10 DC Terminals: M8-1.25 x 15 Grounding Screw: M4-0.7 x 12		
Dimensions	13.4 x 7.6 x 2.8in 340 x 193 x 71mm	15.8 x 9.8 x 3.8in 401 x 249 x 96mm	18.6 x 9.78 x 3.78in 472 x 248 x 96mm
Weight	7.5 lbs / 3.4 kg	10.4 lbs / 4.7 kg	13.4 lbs / 6.1 kg

Technical Specifications

Wired Remote Control	
List dimensions	2.8 x 4.3 x 1.3 in / 70 x 110 x 31.8 mm
Wire length	16.4 ft

Dimensions

1000W Inverter (PGH1-10111S)

2000W Inverter (PGH1-20111S)

3000W Inverter (PGH1-30111S)

NOTE

- Dimension tolerance: ± 0.2 in (0.5 mm)

1000W Inverter (PGH1-10111S)

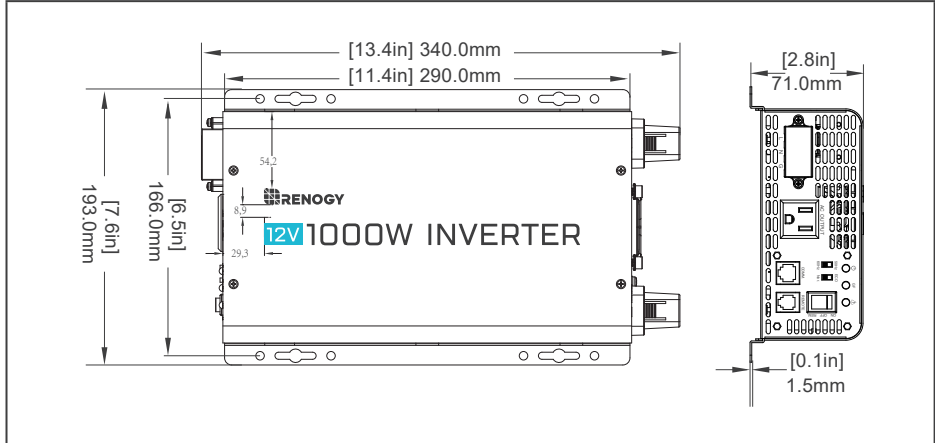

2000W Inverter (PGH1-20111S)

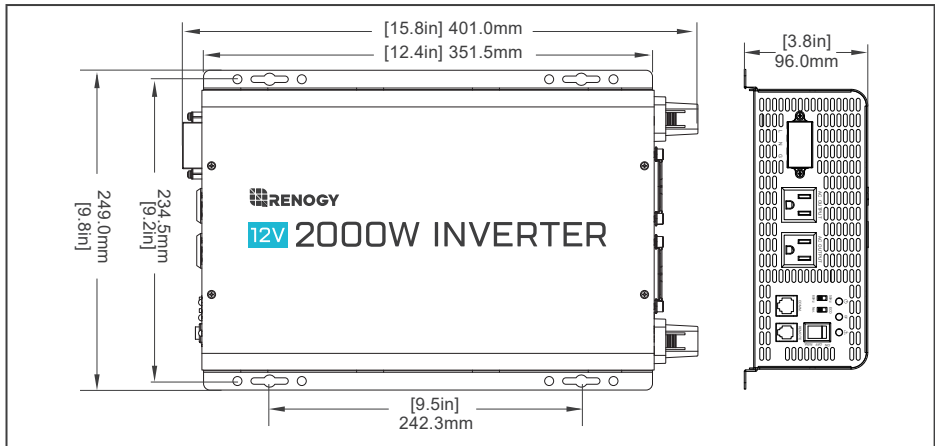

Dimensions

1000W Inverter (PGH1-10111S)

2000W Inverter (PGH1-20111S)

3000W Inverter (PGH1-30111S)

3000W Inverter (PGH1-30111S)

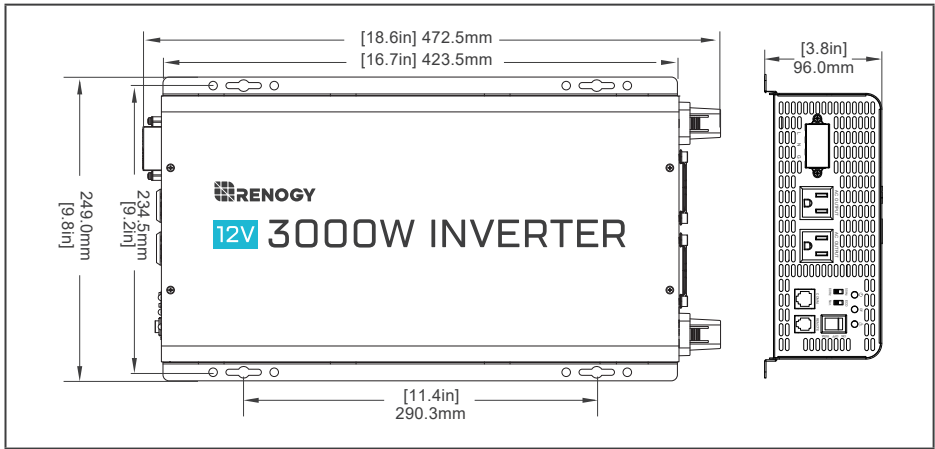

Maintenance

Inspection

Cleaning

Storage

Inspection

For optimum performance, it is recommended to perform these tasks regularly.

- Ensure the inverter is installed in a clean, dry and ventilated area.
- Ensure there is no damage or wear on the cables.
- Ensure the firmness of the connectors and check if there are any loose, damaged or burnt connections.
- Make sure the indicators are in proper condition.
- Ensure there is no corrosion, insulation damage, or discoloration marks of overheating or burning.
- If the inverter is dirty, use a damp cloth to clean the outside of the device to prevent dust and dirt from accumulating. Before the inverter is powered on, make sure it is completely dry after cleaning.
- Make sure the ventilation holes are not blocked.



WARNING

- Risk of electric shock! Make sure that all power supplies are turned off before touching terminals on the inverter.

Cleaning

Follow the steps below to clean the inverter regularly.

- Disconnect all cables connected to the inverter.
- Wear proper protective equipment and use insulated tools during operation. Be careful when touching bare terminals of capacitors as they may retain high lethal voltages even after power is removed.
- Wipe the housing of the inverter and connector contacts with a dry cloth or nonmetallic brush. If it is still dirty, you can use household cleaners.
- Make sure the ventilation holes are not blocked.
- Dry the inverter with a clean cloth and keep the area around the inverter clean and dry.
- Make sure the inverter charger is completely dry before reconnecting it to the battery and AC output.

Storage

Follow the tips below to ensure that the inverter is stored well.

- Disconnect all cables connected to the inverter.
- By applying dielectric grease to each connector contact, the dielectric grease repels moisture and protects the connector contacts from corrosion.
- Store the inverter in a well-ventilated, dry, and clean environment with the temperature between -40°F to 158°F or -40°C to 70°C.

Emergency Responses

Fire

Flooding

Smell

Noise

In the event of any threat to health or safety, always begin with the steps below before addressing other suggestions.

- Immediately contact the fire department or other relevant emergency response team.
- Notify all people who might be affected and ensure that they can evacuate the area.



WARNING

- Only perform the suggested actions below if it is safe to do so.

Fire

1. Disconnect all cables connected to the inverter.
2. Put out the fire with a fire extinguisher. Acceptable fire extinguishers include water, CO₂, and ABC.



WARNING

- Do not use type D (flammable metal) fire extinguishers.

Flooding

1. If the inverter is submerged in water, stay away from the water.
2. Disconnect all cables connected to the inverter.

Smell

1. Ventilate the room.
2. Disconnect all cables connected to the inverter.
3. Ensure that nothing is in contact with the inverter.

Noise

1. Disconnect all cables connected to the inverter.
2. Make sure no foreign objects are stuck in the fan of the inverter or the ring terminal.

Technical Support

For additional support, contact the Renogy technical support team through [renogy.com/contact-us](https://www.renogy.com/contact-us). Have the following information available when contacting Renogy.

- Owner name
- Contact information
- Order number
- Purchase channel
- Serial number
- Brief description of the issue



Renogy offers premium services worldwide:

North America	US	www.renogy.com	CA	ca.renogy.com
Asia	CN	www.renogy.cn	JP	renogy.jp
	KR	kr.renogy.com		
Oceania	AU	au.renogy.com		
Europe	FR	fr.renogy.com	DE	de.renogy.com
	ES	es.renogy.com	UK	uk.renogy.com



Renogy Empowered

Renogy aims to empower people around the world through education and distribution of DIYfriendly renewable energy solutions.

We intend to be a driving force for sustainable living and energy independence.

In support of this effort, our range of solar products makes it possible for you to minimize your carbon footprint by reducing the need for grid power.



Live Sustainably with Renogy

Did you know? In a given month, a 1KW solar energy system will...



Save 170 pounds of coal from being burned



Save 300 pounds of CO₂ from being released into the atmosphere



Save 105 gallons of water from being consumed



Renogy Power **PLUS**

Renogy Power Plus allows you to stay in the loop with upcoming solar energy innovations, share your experiences with your solar energy journey, and connect with like-minded people who are changing the world in the Renogy Power Plus community.

Also, follow us on Youtube @Renogy Solar, Facebook @Renogy, and Instagram @renogyofficial.

Visit renogy.com to find relevant documentation or get more support via "[Contact Us](#)".
Renogy reserves the right to change the contents of this manual without notice.

Join the Renogy Power Plus Community
by downloading the DC Home app.
Find your e-warranty here, and more.

