

Renogy

Dual Input DC-DC On-Board with MPPT Battery Charger

12V/24V 50A | IP67

RBC2125DS-21W



Find Your Energy Freedom™

VERSION A0
January 16, 2024

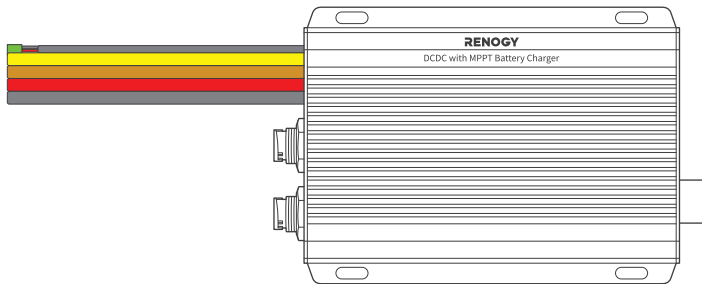

QUICK GUIDE

Before Getting Started

The quick guide provides important operation and maintenance instructions for Renogy 12V/24V 50A IP67 Dual Input DC-DC On-Board with MPPT Battery Charger (hereinafter referred to as battery charger).

Read the quick guide carefully before operation and save it for future reference. Failure to observe the instructions or precautions in the quick guide can result in electrical shock, serious injury, or death, or can damage the battery charger, potentially rendering it inoperable.

Online Manual

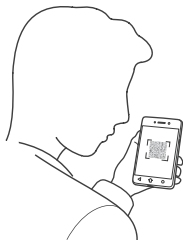

Quick Guide



User Manual



Table of Contents

What's In the Box?	1
Dimensions	2
Get to Know Renogy Battery Charger	3
System Setup	5
Recommended Tools & Accessories	6
Howto Size Wires?	8
How to Install 15/32 in Lugs or 3/8 in Lugs?	9
How to Install Cables on the Battery Charger?	11
Step 1. Plan a Mounting Site	13
Step 2. Connect the Battery Charger to a Busbar	14
Step 3. Connect the Battery Charger to an Auxiliary Battery	15
Step 4. Connect the Battery Charger to a Solar Panel	17
Step 5. Connect the Battery Charger to a Starter Battery	19
Step 6. Install a Battery Temperature Sensor	21
LED Indicators	22

Set a Battery Type	24
USER Mode	25
Monitor the Battery Charger	26
Short-Range Monitoring via DC Home App	27
Wireless Long-Range Monitoring.....	28
Important Safety Instructions	29
Renogy Support	31
FCC Statement.....	33
FCC Radiation Exposure Statement.....	34
Disclaimer	34

What's In the Box?

Renogy 12V/24V 50A IP67
Dual Input DC-DC On-Board
with MPPT Battery Charger x 1

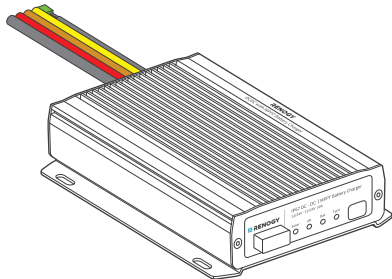

Quick Guide x 1

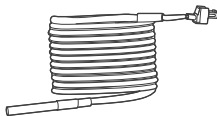

Battery Temperature
Sensor (3 m) x 1

ST4*20 mm



Mounting Screws x 4

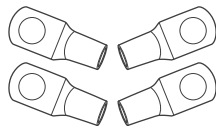

15/32 in Lugs
(M12 Ring Terminals) x 4



Make sure that all accessories are complete and free of any signs of damage.



The accessories and product manual listed are crucial for the installation, excluding warranty information and any additional items. Please note that the package contents may vary depending on the specific product model.



The 15/32-inch lugs (M12 ring terminals) are used to connect starter battery on your vehicle to your auxiliary battery.

Dimensions

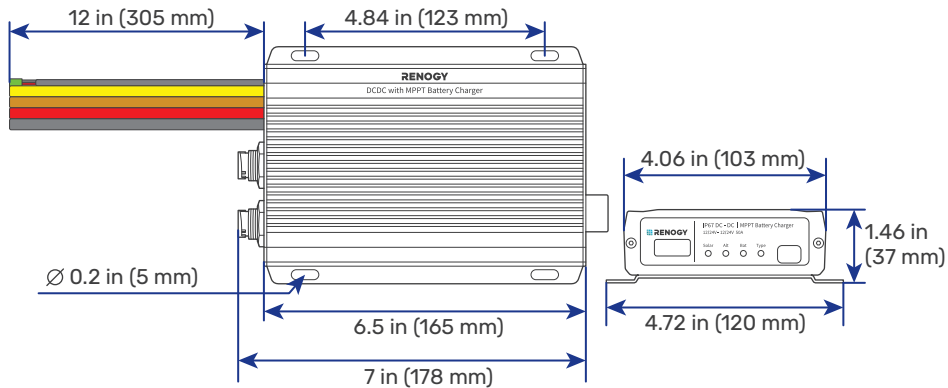

Dimension tolerance: ± 0.2 in (0.5 mm)

Get to Know Renogy Battery Charger

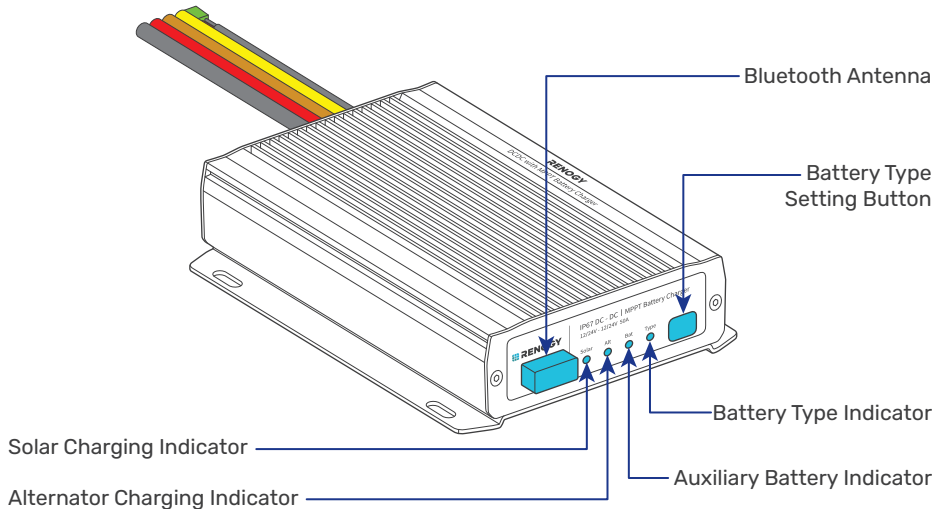

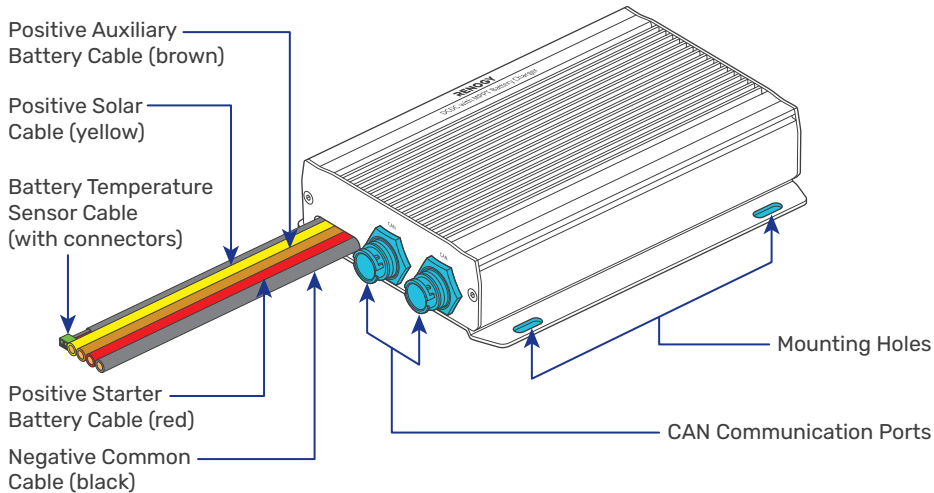

The battery temperature sensor cable can only be used with lead-acid batteries.



For CAN Communication Ports wiring details, refer to the user manual of the battery charger at <https://www.renogy.com/support/downloads>.

System Setup

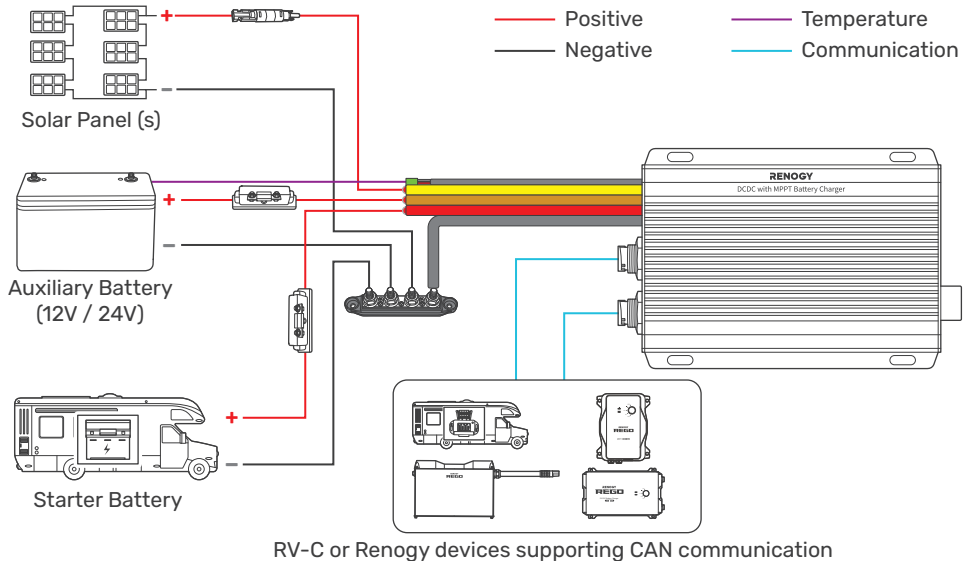

Recommended Tools & Accessories



Phillips
Screwdriver (#1)

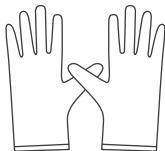

Insulating Gloves



Wire stripper

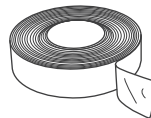

Insulation Tape

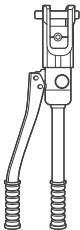

Manual Hydraulic Pliers

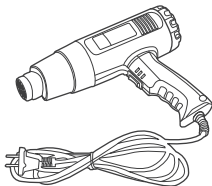

Heat Gun

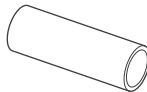

Heat Shrink Tubing

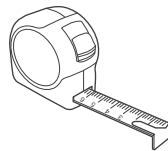

Measuring Tape

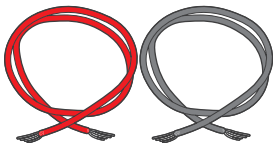

Bare Wires

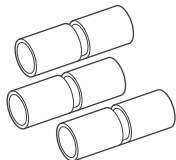

Butt-Splices

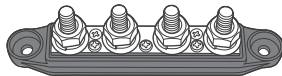

Busbar (60A to 100A)

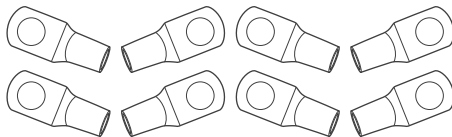

3/8 in Lugs (M10 Ring Terminals)



Prior to installing and configuring the battery charger, prepare the recommended tools, components, and accessories.



The 3/8-inch lugs (M10 ring terminals) are used to connect the busbar and ANL fuse.



For how to size bare wires, refer to [“How to Size Wires?”](#) in this manual.



In this manual, the red cable represents the positive cable, and the gray cable represents the negative cable.

Howto Size Wires?

Select proper bare wires based on the cable length in your power system. Refer to the table below for recommended gauge sizes.

Cable	Cable Length	Cable Gauge Size
Output (to Auxiliary Battery) and Input (from Starter Battery)	0 ft to 10 ft (0 m to 3 m)	10 AWG (5.25 mm ²)
	11 ft to 20 ft (3 m to 6 m)	8 AWG (8.36 mm ²)
	21 ft to 30 ft (6 m to 9 m)	6 AWG (13.3 mm ²)
Input (from Solar Panel)	0 ft to 10 ft (0 m to 3 m)	12 AWG (3.31 mm ²)
	11 ft to 20 ft (3 m to 6 m)	10 AWG (5.25 mm ²)
	21 ft to 30 ft (6 m to 9 m)	10 AWG (5.25 mm ²)



The cable specifications listed above account for critical, less than 3% voltage drop and may not account for all configurations.



The specification of fuse cable is consistent with the input or output terminal of the battery charger.

How to Install 15/32 in Lugs or 3/8 in Lugs?

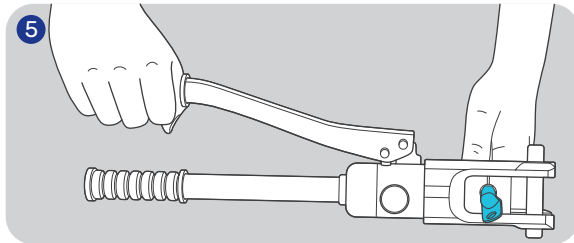
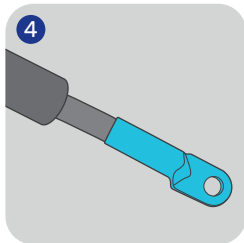
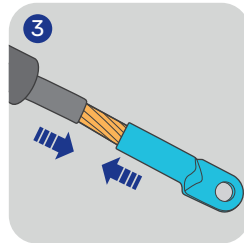
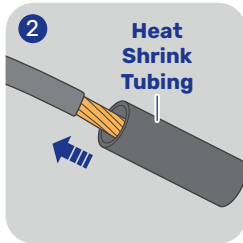
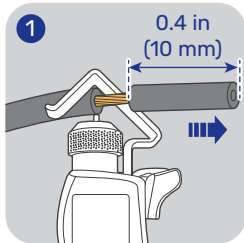

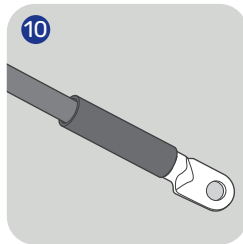
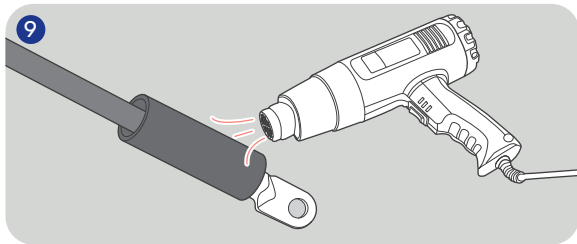
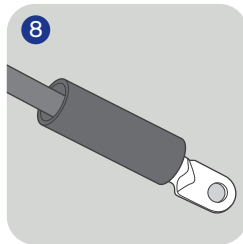
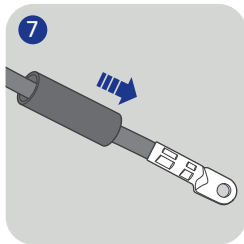
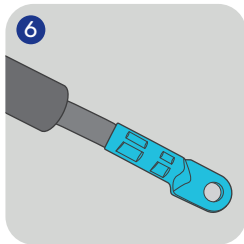

How to Install Cables on the Battery Charger?

■ Positive Cable

The illustrations are based on the Positive Auxiliary Battery Cable. The butt-splice connectors we use in the manual come in separate butt-splices and heat shrink tubings.

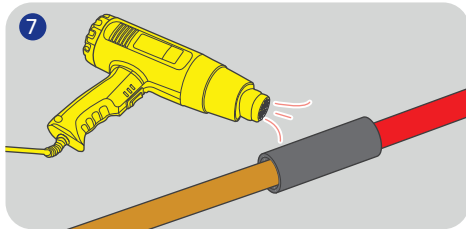
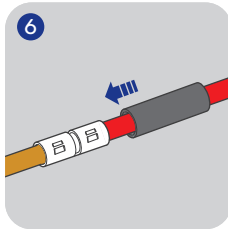
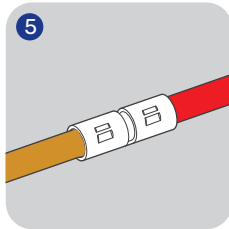
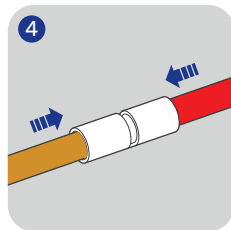
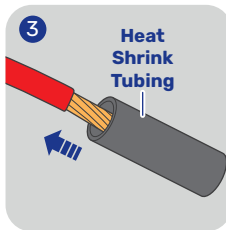
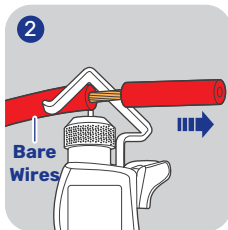
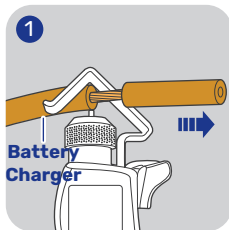

■ Negative Cable

For the negative terminals, we recommend a busbar. Install the 3/8-inch lugs (M10 ring terminals) on the solar panel, auxiliary battery, starter battery negative cables, and battery charger negative common cable (black) on the busbar.

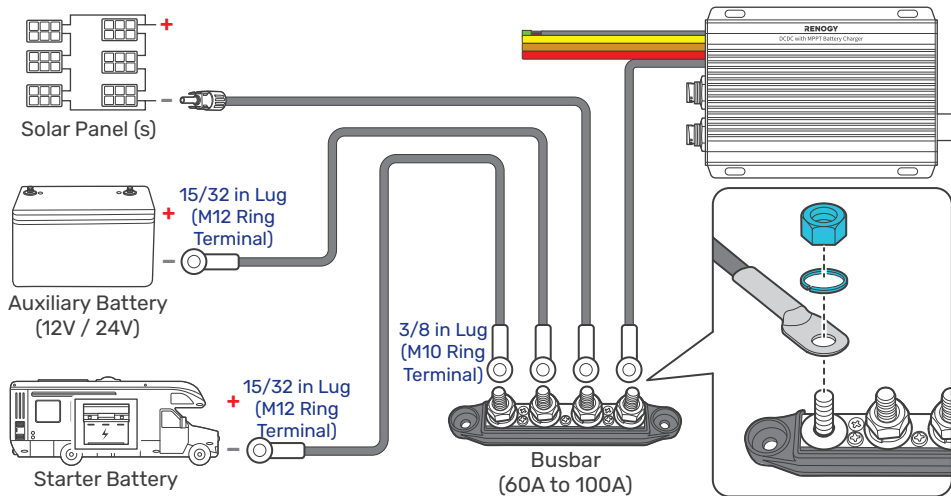

Step 1. Plan a Mounting Site

The battery charger requires adequate clearance for installation, wiring, and ventilation. The minimum clearance is provided below.

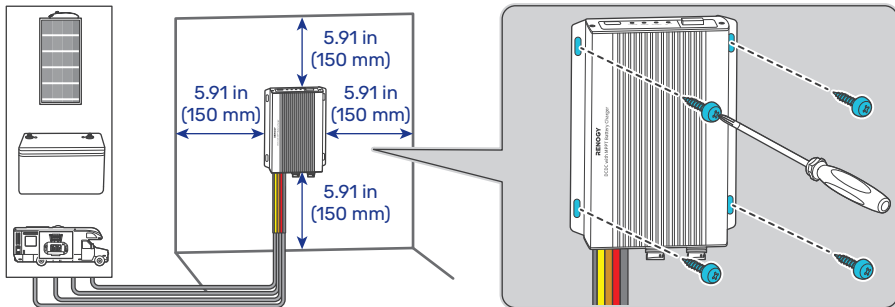

-31°F to 176°F
-35°C to 80°C



0% to 95%



FRAGILE



VENTILATION



The battery charger should be installed on a flat surface protected from direct sunlight.

Step 2. Connect the Battery Charger to a Busbar

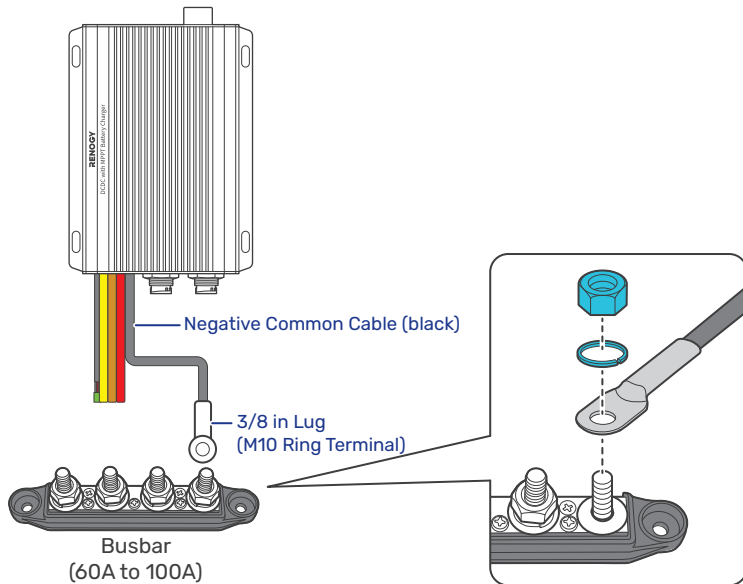

Step 3. Connect the Battery Charger to an Auxiliary Battery

The battery charger can only be connected to 12V or 24V deep-cycle gel-sealed lead-acid batteries (GEL), flooded lead-acid batteries (FLD), sealed lead-acid batteries (SLD/AGM) or lithium iron phosphate batteries (LI).

Recommended Components & Accessories

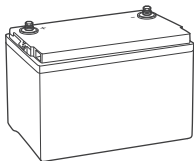

*12V/24V Battery (11V to 32V)

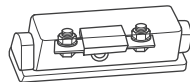

*ANL Fuse (60A) × 1



Components and accessories marked with “*” are available on [renogy.com](https://www.renogy.com).



For installation details, see the user manual of the battery in use.



Always connect the battery charger to a battery before connecting it to a solar panel to ensure safe and efficient operation.

STEP-1 Install cables on the battery charger

Positive Auxiliary
Battery Cable (brown)

Positive Cable
(red bare wire)



STEP-2 Install an ANL fuse

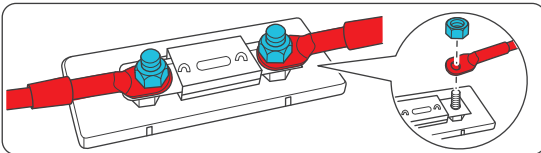

3/8 in Lug

ANL Fuse (60A)

3/8 in Lug

STEP-3 Install the cables on the battery

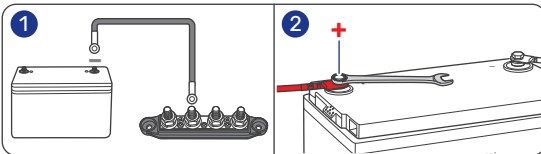

15/32 in Lug

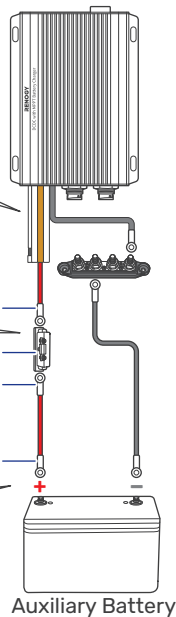

Step 4. Connect the Battery Charger to a Solar Panel

- For 12V batteries, the maximum charging current from solar panels is 50A.
- For 24V batteries, the maximum charging current from solar panels is 25A.

Recommended Components & Accessories

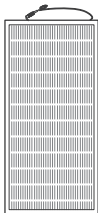

*Solar Panel (s)

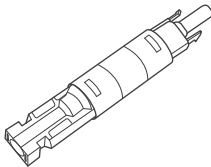

*Solar Panel Fuse



*Solar Panel Extension Cables



Components and accessories marked with "*" are available on [renogy.com](https://www.renogy.com).



Connecting the battery charger to a solar panel exceeding 720W ($\leq 50V$) results in damage to the battery charger.



The appropriate current rating for the solar panel fuse should be determined by multiplying the total short current amperage of the solar panel array by 1.56.

STEP-1 Install cables on the battery charger

Positive Solar Cable (yellow) of the Battery Charger

Solar Panel Extension Cable



STEP-2 Install a solar panel fuse

Solar Panel Extension Cable

Solar Panel Fuse

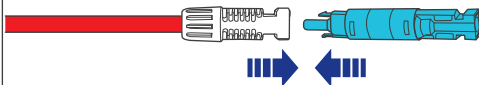

STEP-3 Install the cables on the solar panel

1

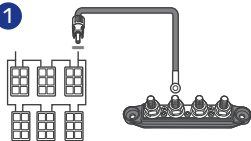

2

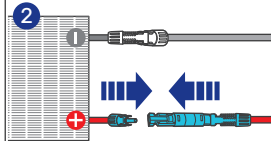

Solar Panel Extension Cables

Solar Panel Fuse

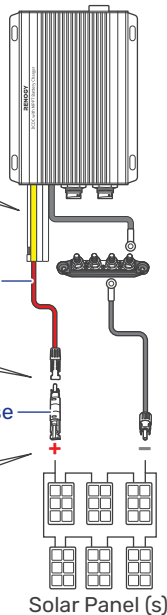

Step 5. Connect the Battery Charger to a Starter Battery

Before installing the charger, consult your vehicle's user manual or contact the vehicle manufacturer to ensure that the output current ranges from 75A to 100A.

The starter battery stops charging the auxiliary battery when the starter battery voltage drops below 12.7V for 12V systems or 25.4V for 24V systems.

Recommended Accessories

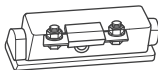

*ANL Fuse (70A) × 1



Accessories marked with "*" are available on [renogy.com](https://www.renogy.com).



The starter battery stops charging the auxiliary battery when the starter battery voltage drops below 12.7V for 12V systems or 25.4V for 24V systems.



The battery charger can be connected separately to the solar panel for charging the auxiliary battery or to the vehicle's starting battery for charging the auxiliary battery.

STEP-1 Install cables on the battery charger

Positive Starter
Battery Cable (red)
of the Battery Charger

Positive Cable
(red bare wire)



STEP-2 Install an ANL fuse

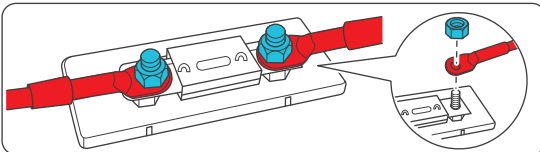

STEP-3 Install the cables on the RV starter battery

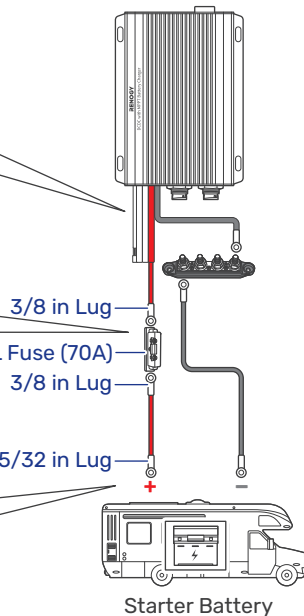
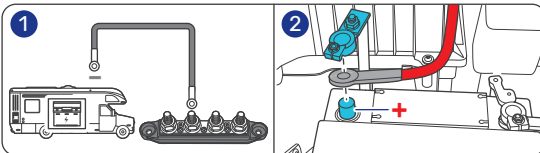

Step 6. Install a Battery Temperature Sensor

The temperature sensor measures the surrounding temperature of the battery and compensates the floating charge voltage when the battery temperature is low.



Do not use the temperature sensor on a LiFePO₄ (LFP) battery which comes with a battery management system (BMS).

Mount the sensor securely at a suitable location in close proximity to the battery.

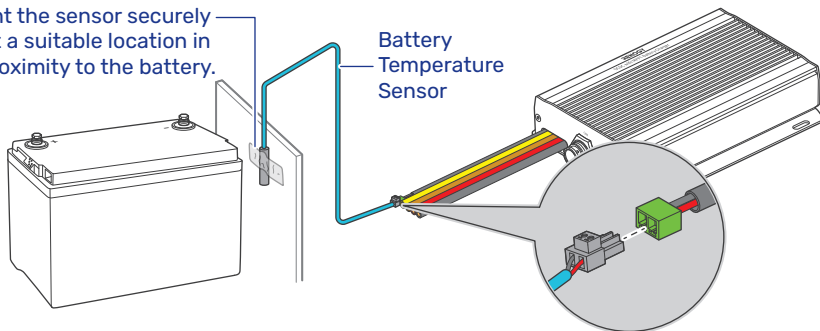

LED Indicators

The battery charger turns on automatically after power on with the LED indicators working in accordance with the relative operating status.

Solar Charging Indicator

- **Off:** Not charging
- **Solid:** MPPT charging
- **Slow flash:** Boost charging
- **Single flash:** Float charging
- **Double flash:** Limited-current charging
- **Fast flash:** Equalization charging

Alternator Charging Indicator

- **Off:** Not charging
- **Solid:** The starter battery connected to the alternator is charging the auxiliary battery.
- **Slow flash:** The solar panel is charging the starter battery.







Battery Type Indicator

- **Solid:** FLD
- **Solid:** GEL
- **Solid:** SLD/AGM
- **Solid:** 12V LI
- **Solid:** 24V LI
- **Solid:** User Mode

Auxiliary Battery Indicator

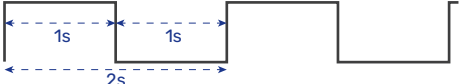
- **Off:** No battery detected
- **Solid:** Full charge
- **Solid:** Normal battery voltage
- **Solid:** Undervoltage warning
- **Slow flash:** Overdischarge warning
- **Fast flash:** Overtemperature/Overvoltage warning

Check out the graphic indications of ON, OFF, Solid, Slow Flash, Fast Flash, Single Flash, and Double Flash of LEDs in the table below:

LED ON		LED ON	
LED Pattern	Graphic Expression		
Solid			
Slow Flash			
Fast Flash			
Single Flash			
Double Flash			

Set a Battery Type

Upon installing the battery charger, set a correct battery type by using the Battery Type Setting Button. For non-lithium batteries, the battery charger can automatically detect their voltage (12V or 24V).



It is essential to ensure that the battery type setting is configured correctly to avoid any potential damage to the battery charger because any damage to the battery charger resulting from an incorrect battery type setting voids the warranty.

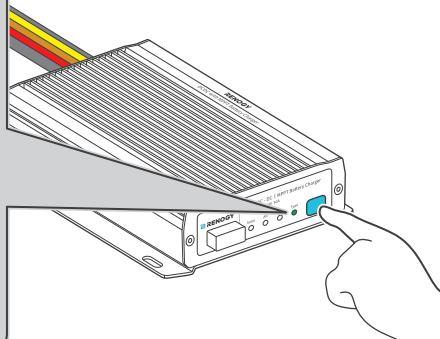
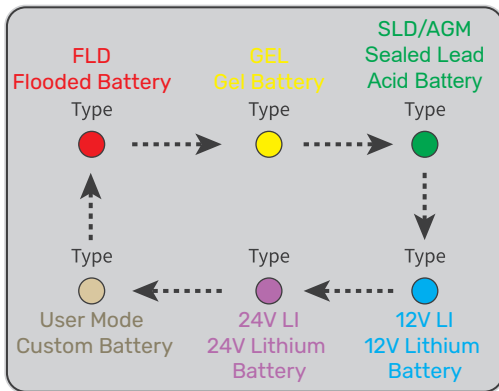

USER Mode

Setting the battery type to User Mode allows you to customize your battery parameters. You can modify the parameters in the DC Home app.

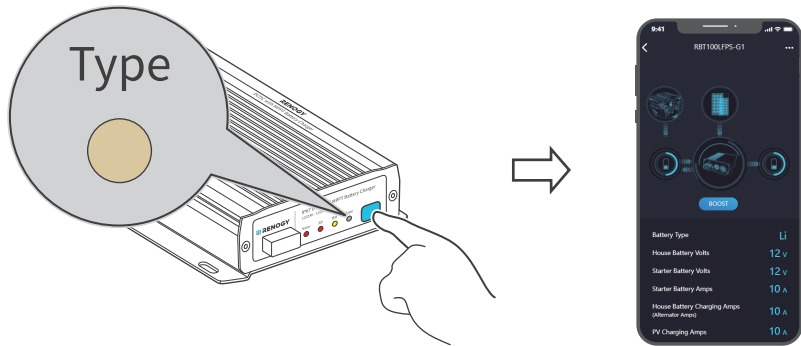

When customizing settings, consult the user manual provided by the battery manufacturer. If necessary, contact the manufacturer for further assistance.



For detailed parameter settings, see the user manual of the battery charger at [renogy.com/support/downloads](https://www.renogy.com/support/downloads).

Monitor the Battery Charger

Download the DC Home app. Login to the app with your account.

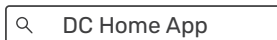
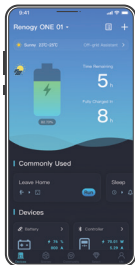

For CAN communication details, see the user manual of the battery charger at renogy.com/support/downloads.



The version of the DC Home app might have been updated. Illustrations in the user manual are for reference only. Follow the instructions based on the current app version.



To ensure optimal system performance, keep the phone or RENOGY ONE within 10 feet (3 m) of the battery charger.



You can receive fault alarms on DC Home and Renogy ONE when the battery charger is faulty. Please login to the DC Home app or Renogy ONE for troubleshooting details.

Short-Range Monitoring via DC Home App

Pair the battery charger with the DC Home app. Monitor and modify the parameters of the battery charger via the app.

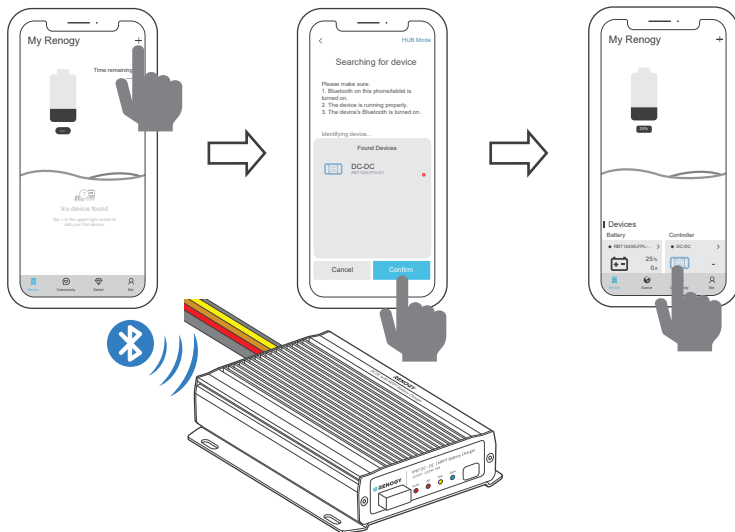

Wireless Long-Range Monitoring

Recommended Components



*RENOGY ONE Core

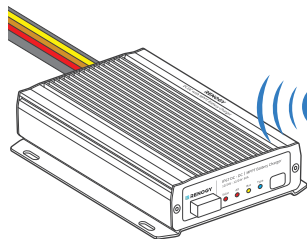

Internet

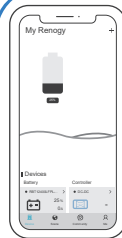

Important Safety Instructions

■ General

- Wear proper protective equipment and use insulated tools during installation and operation. Do not wear jewelry or other metal objects when working on or around the battery charger.
- Keep the battery charger out of the reach of children.
- Do not dispose of the battery charger as household waste. Comply with local, state, and federal laws and regulations and use recycling channels as required.
- In case of fire, put out the fire with a FM-200 or CO₂ fire extinguisher.
- Installing the battery charger improperly on a boat may cause damage to components of the boat. Have the devices installed by a qualified electrician.
- Do not expose the battery charger to flammable or harsh chemicals or vapors.
- Clean the battery charger regularly.
- Do not puncture, drop, crush, penetrate, shake, strike, or step on the battery charger.
- Do not open, disassemble, repair, tamper with, or modify the battery charger.
- Connect the negative prior to the positive terminal when connecting any device.
- It is recommended that all cables should not exceed 10 meters because excessively long cables result in a voltage drop.
- The cable specifications listed in the quick guide account for critical, less than 3% voltage drop and may not account for all configurations.

■ Battery Charger Safety

- Install the battery charger on a vertical surface - protected from direct sunlight, high temperatures, and water. Make sure there is good ventilation.
- Keep the battery charger away from heating equipment.
- Do not insert foreign objects into the battery charger.
- Confirm the polarities of the devices before connection. A reverse polarity contact can result in damage to the battery charger, thus voiding the warranty.
- Do not touch the connector contacts while the battery charger is in operation.
- Disconnect all connectors from the battery charger before maintenance or cleaning.

■ Battery Safety

- Do not use batteries if there is any damage.
- Do not touch the exposed electrolyte or powder if the battery is damaged.
- Risk of explosion! Never install the battery charger in a sealed enclosure with flooded batteries! Do not install the battery charger in a confined area where battery gases can accumulate.
- Prior to installing the battery charger, ensure all battery groups are installed properly.

■ Solar Panel Safety

- Do not use the solar panel(s) if there is any damage.
- Prior to connecting the battery charger to the solar panel(s), shade the solar panel(s).
- Always connect the battery charger to the battery first before connecting it to the solar panel. This prevents damage caused by open-circuit voltage from the solar panel.

Renogy Support

To discuss inaccuracies or omissions in this quick guide or user manual, visit or contact us at:

 | renogy.com/support/downloads



→ contentservice@renogy.com

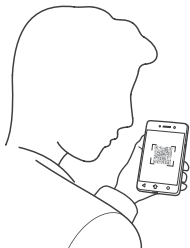

Questionnaire Investigation



To explore more possibilities of solar systems, visit Renogy Learning Center at:

 | renogy.com/learning-center



For technical questions about your product in the U.S.: contact the Renogy technical support team through:

 | renogy.com/contact-us



1(909)2877111

For technical support outside the U.S.: visit the local website below:

Canada |  | ca.renogy.com

Australia |  | au.renogy.com

South Korea |  | kr.renogy.com

United Kingdom |  | uk.renogy.com

China |  | www.renogy.cn

Japan |  | renogy.jp

Germany |  | de.renogy.com

Other Europe |  | eu.renogy.com

FCC Statement

This device complies with Part 15 of the FCC Rules. Operation is subject to the following two conditions:

- (1) This device may not cause harmful interference.
- (2) This device must accept any interference received, including interference that may cause undesired operation.

Any Changes or modifications not expressly approved by the party responsible for compliance could void the user's authority to operate the equipment.

This equipment has been tested and found to comply with the limits for a Class B digital device, pursuant to Part 15 of the FCC Rules. These limits are designed to provide reasonable protection against harmful interference in a residential installation. This equipment generates, uses and can radiate radio frequency energy and, if not installed and used in accordance with the instructions, may cause harmful interference to radio communications. However, there is no guarantee that interference will not occur in a particular installation. If this equipment does cause harmful interference to radio or television reception, which can be determined by turning the equipment off and on, the user is encouraged to try to correct the interference by one or more of the following measures:

- (1) Reorient or relocate the receiving antenna.
- (2) Increase the separation between the equipment and receiver.
- (3) Connect the equipment into an outlet on a circuit different from that to which the receiver is connected.
- (4) Consult the dealer or an experienced radio/TV technician for help.

FCC Radiation Exposure Statement

This equipment complies with FCC radiation exposure limits set forth for an uncontrolled environment. This equipment should be installed and operated with minimum distance 20cm between the radiator & your body.

Disclaimer

Renogy 12V/24V 50A IP67 Dual Input DC-DC On-Board with MPPT Battery Charger Quick Guide © 2024 Renogy. All rights reserved.

RENOGY and **RENOGY** are registered trademarks of Renogy.

- All information in the quick guide is subject to copyright and other intellectual property rights of Renogy and its licensors. The quick guide may not be modified, reproduced, or copied, in whole or in part, without the prior written permissions of Renogy and its licensors.
- The registered trademarks in the quick guide are the property of Renogy. The unauthorized use of the trademarks is strictly prohibited.
- Renogy ensures the accuracy, sufficiency, and the applicability of information in the quick guide at the time of printing due to continual product improvements that may occur.

- Renogy assumes no responsibility or liability for personal and property losses, whether directly and indirectly, caused by the user's failure to install and use the product in compliance with the quick guide.
- Renogy is not responsible or liable for any failure, damage, or injury resulting from repair attempts by unqualified personnel, improper installation, and unsuitable operation.
- The illustrations in the quick guide are for demonstration purposes only. Details may appear slightly different depending on product revision and market region.
- Renogy reserves the right to change the information in the quick guide without notice. For the latest quick guide, visit [renogy.com](https://www.renogy.com).



Renogy Power PLUS

Renogy Power Plus allows you to stay in the loop with upcoming solar energy innovations, share your experiences with your solar energy journey, and connect with like-minded people who are changing the world in the Renogy Power Plus community.



@Renogy Solar



@renogyofficial



@Renogy

Renogy reserves the right to change the contents of this quick guide without notice.

Manufacturer: RENOGY New Energy Co.,Ltd

Address: No.66, East Ningbo Road Room 624-625

Taicang German Overseas Students Pioneer Park
JiangSu 215000 CN



eVatmaster Consulting GmbH
Battinastr. 30
60325 Frankfurt am Main, Germany
contact@evatmaster.com

Manufacturer: RENOGY New Energy Co.,Ltd

Address: No.66, East Ningbo Road Room 624-625

Taicang German Overseas Students Pioneer Park
JiangSu 215000 CN



EVATOST CONSULTING LTD
Suite 11, First Floor, Moy Road Business
Centre, Taffs Well, Cardiff, Wales, CF15 7QR
contact@evatmaster.com

RENOGY.COM