

RENOGY 1000

Portable Power Station

Version A0



APPLICABILITY

The User Manual applies to the following product:

- RENOGY 1000 Portable Power Station (RPS100150AA-PCS)

DISCLAIMER

- Renogy makes no warranty as to the accuracy, sufficiency, or suitability of information in the User Manual because continuous product improvements are going to be made.
- Renogy assumes no responsibility or liability for losses or damages, whether direct, indirect, consequential, or incidental, which might arise out of the use of information in the User Manual.
- Renogy is not responsible or liable for the failures, damages, or injuries resulting from repair attempted by unqualified personnel or improper installation and operation.
- The illustrations in the User Manual are for demonstration purposes only. Details may appear slightly different depending on product revision and market region.
- Renogy reserves the right to change the information in the User Manual without notice.

COPYRIGHT

RENOGY 1000 Portable Power Station User Manual © 2022 Renogy. All rights reserved.

All information in the User Manual is subject to copyright and other intellectual property rights of Renogy and its licensors. The User Manual may not be modified, reproduced, or copied, in whole or in part, without the prior written permissions of Renogy and its licensors.

TRADEMARKS

The following are trademarks or registered trademarks of Renogy in the United States and other countries:

| | |
|--------|---------------|
| RENOGY | RENOGY |
|--------|---------------|

All other trademarks in the User Manual are the property of their respective owners and their use herein does not imply sponsorship or endorsement of their products or services. The unauthorized use of any trademark displayed in the User Manual or on the product is strictly prohibited.

Important Safety Instructions

Please save these instructions.

The User Manual provides important operation and maintenance instructions for RENOGY 1000 Portable Power Station (hereinafter referred to as Portable Power Station). Please read the User Manual carefully before operation and save it for future reference. Failure to observe the instructions or precautions in the User Manual can result in electrical shock, serious injury, or death, or can damage the portable power station, potentially rendering it inoperable.

■ **Symbols Used**

The following symbols are used throughout the User Manual to highlight important information.

WARNING

Indicates a potentially dangerous condition which could result in injury or death.

CAUTION

Indicates a critical procedure for safe and proper installation and operation.

NOTE

Indicates an important step or tip for optimal performance.

■ **General Safety Information**

WARNING

- DO NOT immerse the portable power station in water or leave it out in the rain.
- DO NOT puncture, drop, crush, penetrate, shake, strike, or step on the portable power station.
- DO NOT open, dismantle, repair, tamper with, or modify the portable power station.
- DO NOT insert foreign objects into the casing or outlets of the portable power station.
- Please remove all connections and turn the portable power station off before cleaning it.
- DO NOT expose the portable power station to direct flame.
- Please keep the portable power station away from flammable or combustible materials.
- Please keep the portable power station away from heating equipment.
- DO NOT touch the exposed electrolyte or powder if the portable power station is damaged.
- DO NOT use the portable power station with life support equipment or other medical equipment.
- Please keep the portable power station out of the reach of young children.
- DO NOT dispose of the portable power station as household waste. Please recycle the portable power station in accordance with local, state, and federal regulations.
- Please inspect the portable power station before each use. Stop using the portable power station if any visible damages including cracks, dents, and deformation or abnormalities including unusual smells and heating are observed.

CAUTION

- Please use the portable power station in accordance with its input and output specifications.
- DO NOT expose the portable power station to flammable or harsh chemicals or vapors.
- DO NOT expose the portable power station to strong electrostatic fields, strong magnetic fields, or radiation.
- Please ensure that no water sources including downspouts, sprinklers, or faucets are above or near the portable power station.
- Please ensure that snow does not accumulate around the portable power station.
- DO NOT lean on, stack anything on top of, or hang anything from the portable power station or from cables leading to the portable power station.
- Please ensure that the portable power station is securely fastened during transportation.

Table of Contents

| | |
|----------------------------|----|
| Product Overview | 05 |
| Identification of Parts | 05 |
| Package Content | 07 |
| LCD Display | 08 |
| Operation | 10 |
| Turning On/Off | 10 |
| DC Home Connection | 10 |
| Charging | 13 |
| Powering Devices | 15 |
| Standby Power Supply (SPS) | 17 |
| Parallel Connection | 18 |
| Strip Lights Operation | 20 |
| Timeout Settings | 20 |
| Maintenance | 22 |
| Cleaning | 22 |
| Storage | 22 |
| Troubleshooting | 23 |
| Specifications | 28 |

Product Overview

Identification of Parts

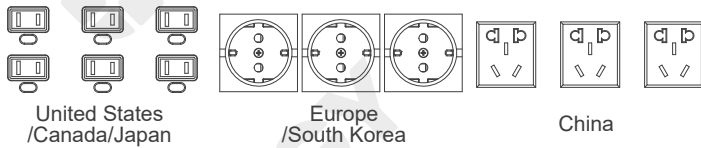
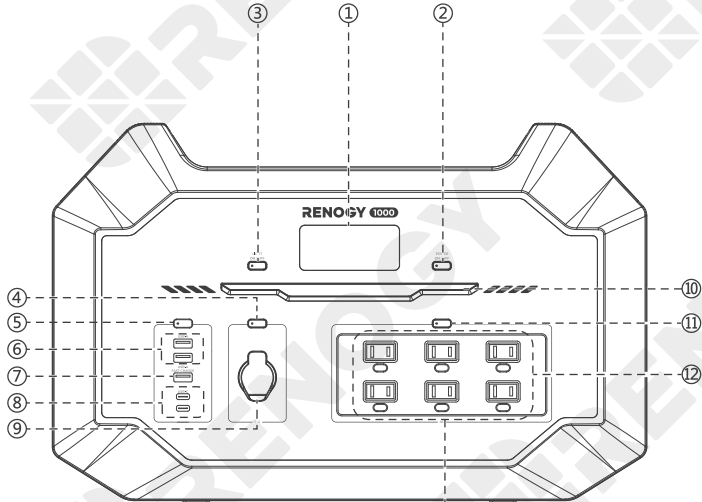

United States
/Canada/Japan

Europe
/South Korea

China

United Kingdom

Australia

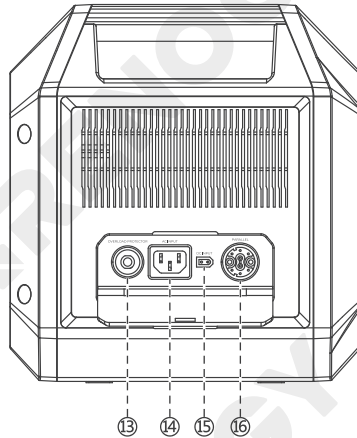

- ① LCD Display
- ② Power On/Off Button
- ③ Light On/Off Button
- ④ CIG On/Off Button
- ⑤ USB On/Off Button
- ⑥ USB-A Ports
- ⑦ USB-A Fast Charge Port
- ⑧ USB-C Ports

- ⑨ CIG Port
- ⑩ LED Strip Lights
- ⑪ AC On/Off Button
- ⑫ AC Outlets
- ⑬ Overload Protector
- ⑭ AC Inlet
- ⑮ DC Input Port
- ⑯ Parallel Outlet

■ Package Content

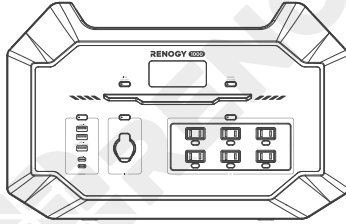

RENLOGY 1000
Portable Power Station



AC Power
Cable



Solar Charge
Cable



Car Charge
Cable

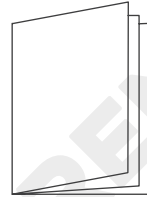





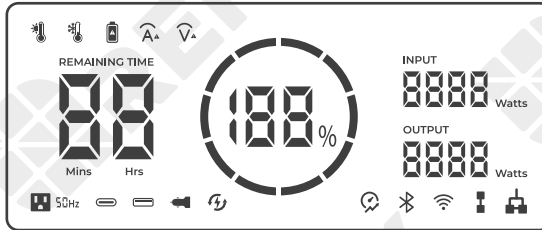







User Manual

LCD Display



| Icon | Name | Description |
|------|-------------------|--|
| | Battery Level | Indicates the current battery level. As the portable power station charges, the ring will light up clockwise with the increasing percentage, and the end-most ring segment will fast flash. Once the portable power station is fully charged, all the ring segments will light up and remain solid. As the portable power station discharges, the ring will go out counter-clockwise. When the battery level drops below 10%, the last ring segment will slow flash. |
| | Input Power | Indicates the amount of power going into the portable power station. |
| | Output Power | Indicates the amount of power going out of the portable power station. |
| | Remaining Time | Indicates the amount of time before the portable power station is completely charged or discharged. When the portable power station idles, the remaining time will show 99 hours. |
| | AC Outlet Status | Indicates the on/off status and output frequency of the AC Outlet(s). |
| | USB-C Port Status | Indicates the on/off status of the USB-C Port. |
| | USB-A Port Status | Indicates the on/off status of the USB-A Ports and USB-A Fast Charge Port. |

| Icon | Name | Description |
|---|-----------------------------------|---|
|  | CIG Port Status | Indicates the on/off status of the CIG Port. |
|  | SPS Mode Status | Indicates the on/off status of the SPS mode |
|  | iBoost Mode Status | Indicates the enable/disable status of the iBoost mode. When the iBoost mode takes effect, the icon will slow flash. |
|  | Bluetooth Status | Indicates the connection status of the Bluetooth. |
|  | WiFi Status | Indicates the connection status of the WiFi. |
|  | Single Phase Parallel Mode Status | Indicates the on/off status of the single phase parallel mode. When the single phase parallel mode is initializing, the icon will slow flash. |
|  | Split Phase Parallel Mode Status | Indicates the on/off status of the split phase parallel mode. When the split phase parallel mode is initializing, the icon will slow flash. |
|  | High Temperature Protection | Indicates the protection related to high temperatures. |
|  | Low Temperature Protection | Indicates the protection related to low temperatures. |
|  | Battery Protection | Indicates the protection related to the internal battery. |
|  | Current Protection | Indicates the protection related to current. |
|  | Voltage Protection | Indicates the protection related to voltage. |

CAUTION

- The portable power station might need special attention if the [High Temperature Protection], [Low Temperature Protection], [Battery Protection], [Current Protection], or [Voltage Protection] icon appears. Please refer to the Troubleshooting section for detailed instructions.

Operation

■ Turning On/Off

- Short press the Power On/Off Button to turn on the portable power station. The LCD Display will light up to display the operating status of the portable power station.
- Long press the Power On/Off Button for 3 seconds to turn off the portable power station. The LCD Display will go out.

■ DC Home Connection

NOTE

- It is required to turn on the portable power station before connecting it to the DC Home app.

Setting Up

- Scan the QR code to download the DC Home app.
- Open the DC Home app. Click “Sign Up” to sign up for a new account.



Bluetooth Connection

- Turn on the Bluetooth on the phone or tablet.
- Click “+” on the top right corner to search for the portable power station.
- Click “Confirm” on the pop-up menu to add the portable power station to the device list.
- Monitor and program the portable power station on the DC Home app.

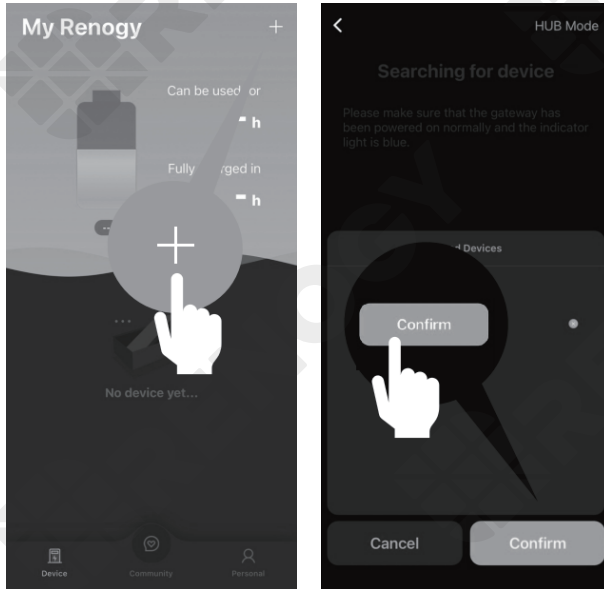

NOTE

- Please keep the phone or tablet within 65.6 feet (20 m) of the portable power station.

WiFi Connection

- Turn on the WiFi and Bluetooth on the phone or tablet.
- Click “+” on the top right corner to search for the portable power station.
- Click “Confirm” on the pop-up menu to add the portable power station to the device list.
- Click “●●●” on the window, and in the next page to configure the WiFi network.
- Select a nearby WiFi network.
- Enter the WiFi password. Click “Connect” to connect the portable power station to the WiFi network.
- Monitor and program the portable power station on the DC Home app from anywhere with the internet access.

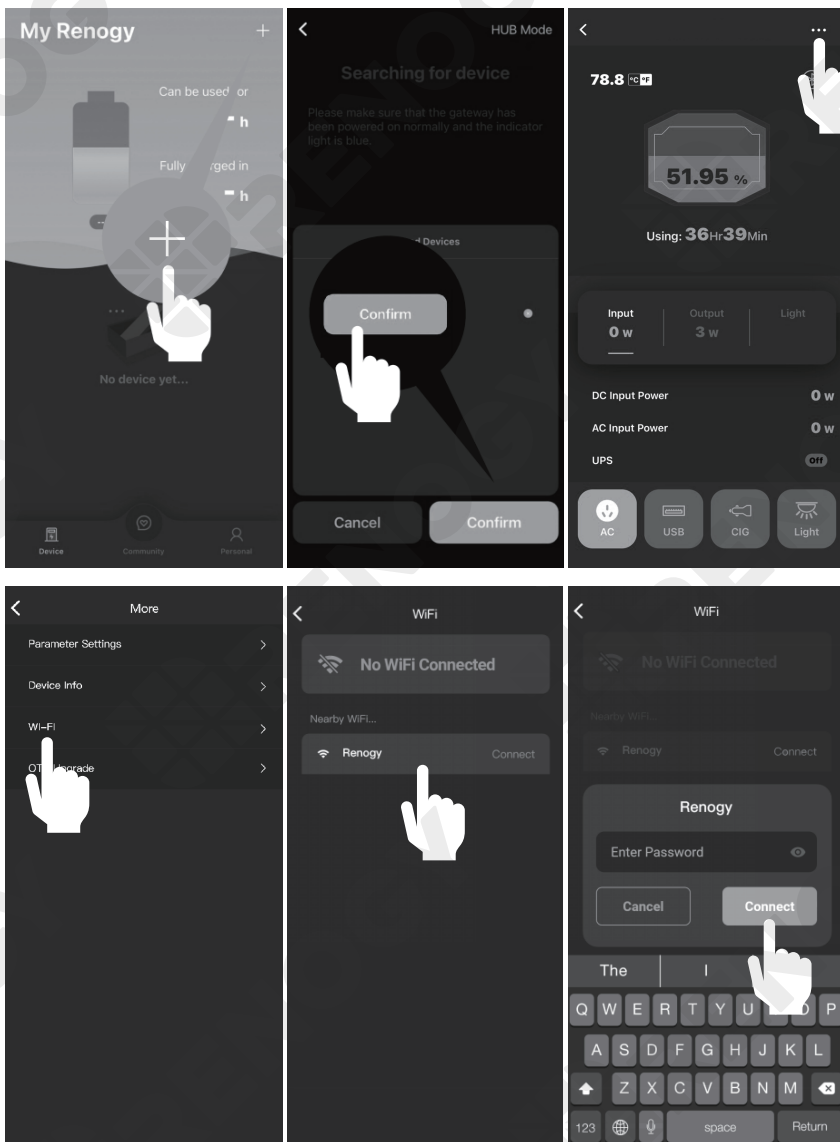

NOTE

- The portable power station only connects to the 2.4GHz WiFi network.

■ Charging

WARNING

- DO NOT charge the portable power station at high temperatures above 131°F (55°C) or low temperatures below 32°F (0°C). The recommended charge temperature range is between 32°F (0°C) and 104°F (40°C).
- DO NOT use damaged accessories to charge the portable power station as it might cause electric shock.

CAUTION

- ONLY use Renogy approved accessories to charge the portable power station.
- DO NOT charge the portable power station immediately after a long heavy run.
- Please charge the portable power station immediately when the battery level drops below 10% to prevent overdischarge.

NOTE

- To extent the cycle life, please fully charge the portable power station before each use.
- It is not required to turn on the portable power station manually before charging. The portable power station turns on automatically once it detects the charging source(s).

The portable power station features 3 charging methods – solar, AC, and car.

Solar Charging

- Place a solar panel (sold separately) under direct sunlight. Steer clear of objects that can shade the solar panel and slow down the charging process.
- Connect the DC Input Port of the portable power station to the solar connectors of the solar panel with the included solar charge cable. The portable power station will start charging automatically.
- Multiple solar panels can be connected in series for a higher power rating.

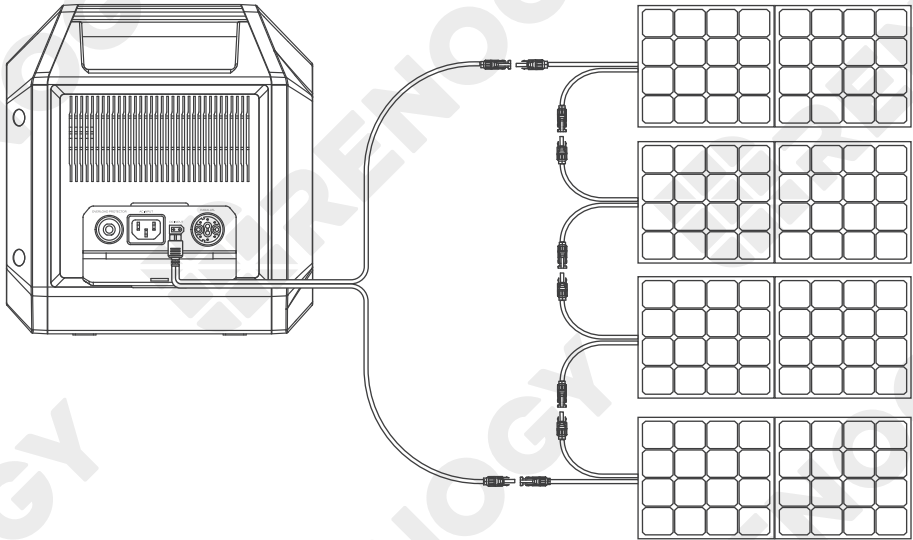

CAUTION

- The operating voltage of the solar panel array shall exceed 10V, and the open circuit voltage shall NOT exceed 100V.
- Please ensure that the solar panels are of the same type and ratings and under similar conditions.

NOTE

- The portable power station automatically limits the input power. It is allowed and recommended to charge the portable power station with a solar panel array rated above 400W to account for the energy conversion loss.
- For optimal charging performance, it is recommended to charge the portable power station with the solar panel array on bright sunny days free of clouds.
- The solar charge time is highly dependent on the solar irradiance and the ambient temperature.

AC Charging

- The iTurbo technology enables the portable power station to be charged up to 80% within 1 hour.
- Connect the AC Inlet of the portable power station to a wall outlet with the included AC Power Cable. The portable power station will start charging automatically.
- The charging speed is set to fast by default. It can be reduced on the DC Home app for a quieter charging experience.

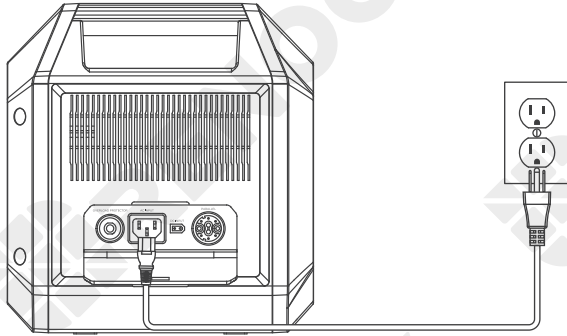

Car Charging

- Start the car engine.
- Connect the DC Input Port of the portable power station to the CIG port in the car with the included Car Charge Cable. The portable power station will start charging automatically.

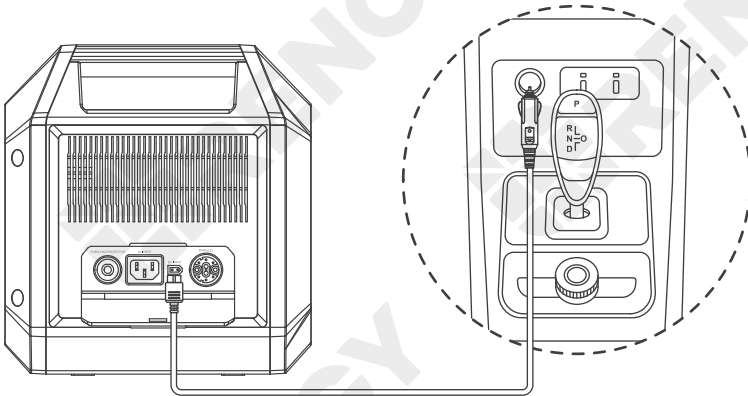

Powering Devices

WARNING

- DO NOT discharge the portable power station at high temperatures above 131°F (55°C) or low temperatures below -4°F (-20°C). The recommended discharge temperature range is between -4°F (-20°C) and 104°F (40°C).

CAUTION

- The portable power station can provide a total output power of up to 2100W. Please allocate the output power rationally. DO NOT overload the portable power station.
- DO NOT connect high power devices to the portable power station when it is running low.

NOTE

- It is required to turn on the portable power station before powering devices.
- When the portable power station is overloaded, it will turn off the USB-A Ports, USB-A Fast Charge Port, and USB-C Port, CIG Port, and AC Outlets in sequence until the total output power drops below 2100W.
- The portable power station might not be able to deliver exact 998.4Wh energy when powering high power devices

The portable power station provides 5 kinds of output ports for the devices – USB-A, USB-A fast charge, USB-C, CIG, and AC.

USB-A/USB-C Devices

- Short press the USB On/Off Button with the portable power station on to turn on the USB-A Ports, USB-A Fast Charge Port, and USB-C Ports. Connect the devices to the USB-A Ports, USB-A Fast Charge Port, or USB-C Ports to start powering the devices.
- Long press the USB On/Off Button for 3 seconds to turn off the USB-A Ports, USB-A Fast Charge Port, and USB-C Ports. The USB-A Ports, USB-A Fast Charge Port, and USB-C Ports will stop powering the devices.
- The USB-A Ports and USB-A Fast Charge Port can power most USB-A devices including smart watch, electronic book, smartphone, tablet, action camera, digital camera, Bluetooth speaker, wireless headphone, and drone.
- The USB-C Ports can power most USB-C devices including smartphone, tablet, laptop, hand-held game console, and DSLR camera.

NOTE

- When both the USB-C Ports are in use, each USB-C Port can only deliver up to 60W output power.
- To get up to 18W output power from the USB-A Fast Charge Port, the USB-A device must support the Quick Charge (QC) standard.
- To get up to 100W output power from the USB-C Port, the USB-C device must support the Power Delivery (PD) standard.

Car Powered Devices

- Short press the CIG On/Off Button with the portable power station on to turn on the CIG Port. Connect the device to the CIG Port to start powering the device.
- Long press the CIG On/Off Button for 3 seconds to turn off the CIG Port. The CIG Port will stop powering the device.
- The CIG Port can power most car powered devices including portable refrigerator, car vacuum, car air fan, and CPAP machine.

AC Devices

- Short press the AC On/Off Button with the portable power station on to turn on the AC Outlets. Connect the devices to the AC Outlets to start powering the devices.
- The output frequency of the AC Outlets can be switched between 50Hz and 60Hz on the DC Home app.
- Long press the AC On/Off Button for 3 seconds to turn off the AC Outlets. The AC Outlets will stop powering the devices.
- The AC Outlets can power most AC devices rated under 1500W including desktop computer, TV, game console, full-size refrigerator, space heater, vacuum, and microwave.
- The iBoost mode allows the AC outlets to power most resistive AC devices rated between 1500W and 3000W including hair dryer, electric kettle, toaster oven, electric grill, electric cook-top, and electric iron.
- The iBoost mode is enabled by default. It can be enabled or disabled manually on the DC Home app.

CAUTION

- Please select the output frequency of the AC Outlets in accordance with the device specifications. Inappropriate output frequency might damage the device.
- Please allow at least 4 inches (101.6 mm) of space on both sides of the portable power station for efficient heat dissipation when the AC Outlets are in use.

NOTE

- The portable power station might not be able to power the AC devices that require high starting currents even though they are rated under 1500W.
- The iBoost mode is not applicable for the inductive and capacitive AC devices with strict voltage limits.

Standby Power Supply (SPS)

NOTE

- It is not required to turn on the portable power station manually before using it as a SPS. The portable power station turns on automatically once it is connected to a wall outlet.

The portable power station can work as a SPS to deliver emergency AC power to the devices during a power outage.

- Connect the AC Inlet of the portable power station to a wall outlet with the included AC Power Cable.
- Short press the AC On/Off Button to turn on the AC Outlets.
- Connect the devices to the AC Outlets. The SPS mode will be turned on automatically with the devices powered by the AC power from the wall outlet.

- In the case of a power outage, the portable power station will deliver emergency AC power to the devices with a transfer time less than 20ms.

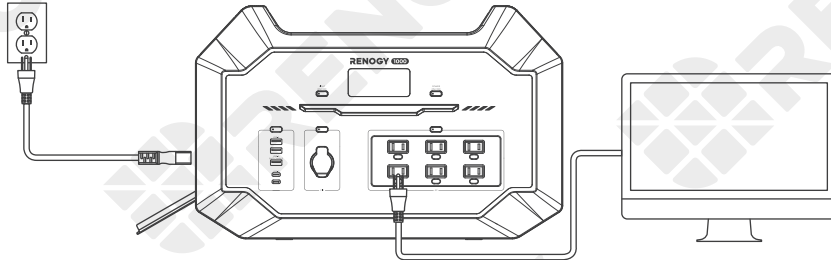

CAUTION

- DO NOT connect AC devices rated over 1500W to the portable power station for emergency AC power.
- DO NOT connect AC devices that require a transfer time less than 20ms including data server and workstation to the portable power station for uninterrupted AC power. Please check the holdup time of the power supply units (PSU) in the AC devices to confirm the compatibility.

NOTE

- The iBoost mode will be automatically disabled when the SPS mode is turned on.

■ Parallel Connection

NOTE

- It is required to turn on the portable power stations before connecting them in parallel.

The iStack technology allows two RENOGY 1000 portable power stations to be connected in parallel to deliver 1996.8Wh capacity and 2700W AC output.

Single Phase Parallel

- Short press the AC On/Off Button with the portable power station on to turn on the AC Outlets.
- Connect the Parallel Outlets of two RENOGY 1000 portable power stations with a single phase parallel kit (sold separately). The single phase parallel mode will be turned on after a few seconds of initialization.
- Connect the devices to the single phase parallel kit to start powering the devices.
- Through the single phase parallel kit, two RENOGY 1000 portable power stations can together power most single phase AC devices rated under 2700W including washing machine, room air conditioner, and vacuum.

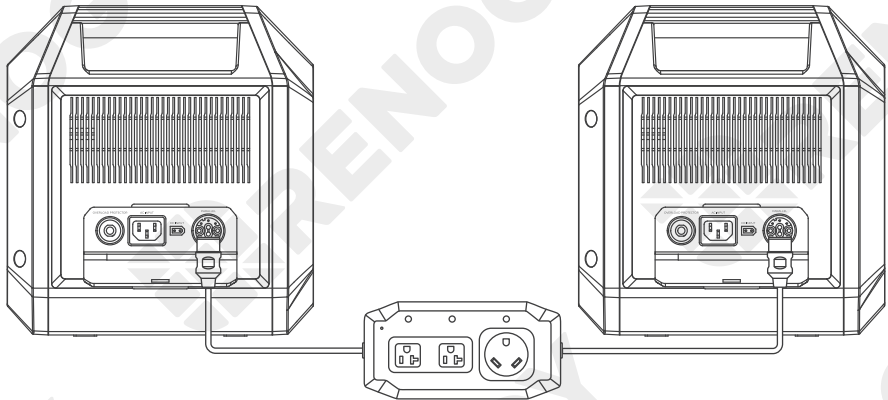

Split Phase Parallel (US/CA/JP Models Only)

- Short press the AC On/Off Button with the portable power station on to turn on the AC Outlets.
- Connect the Parallel Outlets of two RENOGY 1000 portable power stations with a split phase parallel kit (sold separately). The split phase parallel mode will be turned on after a few seconds of initialization.
- Connect the devices to the split phase parallel kit to start powering the devices.
- Through the split phase parallel kit, two RENOGY 1000 portable power stations can together power most split phase AC devices rated under 2700W including baseboard heater, electric clothes dryer, and electric stove.

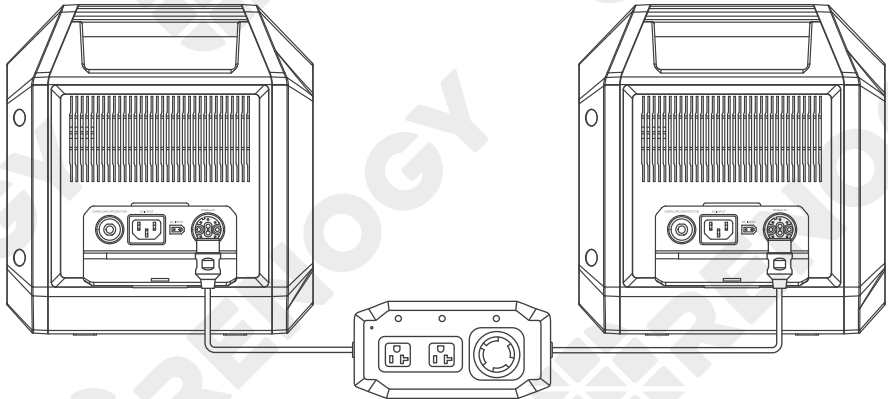

CAUTION

- Please ensure that two RENOGY 1000 portable power stations are of the same model.
- Please ensure that the AC Outlets of the two RENOGY 1000 portable power stations have the same output voltage and output frequency.

NOTE

- The split phase parallel mode is available on US, CA, and JP models only.
- Please read the user manuals of RENOGY Single Phase Parallel Kit and RENOGY Split Phase Parallel Kit before connecting two RENOGY 1000 portable power stations in parallel.
- Please fully charge the two portable power stations before connecting them in parallel.
- The AC Inlet will be disabled for AC charging and SPS mode when the single phase parallel kit or split phase parallel kit is connected to the portable power station.
- The AC Outlets will be turned off temporarily when connecting the two portable power stations in parallel.
- It is not recommended to power devices through the AC Outlets when the two portable power stations are connected in parallel.

Strip Lights Operation

NOTE

- It is required to turn on the portable power station before using the LED Strip Lights.

The LED Strip Lights offer three lighting modes – solid, breath, and flow.

- Short press the Light On/Off Button to turn on the LED Strip Lights, switch the lighting modes, and turn off the LED Strip Lights.
- Long press the Light On/Off Button for 3 seconds to turn off the LED Strip Lights no matter what lighting mode they are on.
- The brightness of the LED Strip Lights can be adjusted on the DC Home app.
- When the portable power station is charging, the LED Strip Lights will automatically turn on in breath mode by default. The LED Strip Lights can be set to off while charging on the DC Home app.

Timeout Settings

LCD Display Timeout

- When no operation is made for 5 minutes, the LCD Display will go out automatically to save energy.
- Short press the Power Button with the portable power station on to light up or dim the LCD Display manually.
- The timeout of the LCD Display can be set or disabled on the DC Home app.

USB Ports Timeout

- When the device draws low or no power from the USB-A Ports, USB-A Fast Charge Port, and USB-C Ports for 1 hour, the USB-A Ports, USB-A Fast Charge Port, and USB-C Ports will turn off automatically to save energy.
- The timeout of the USB-A Ports, USB-A Fast Charge Port, and USB-C Ports can be set or disabled on the DC Home app.

CIG Port/AC Outlets Timeout

- When the device draws low or no power from the CIG Port or AC Outlets for 1 hour, the CIG Port or AC Outlets will turn off automatically to save energy.
- The timeout of the CIG Port or AC Outlets can be set or disabled on the DC Home app.

Unit Timeout

- When the portable power station is not charging and the USB-A Ports, USB-A Fast Charge Port, USB-C Ports, CIG Port, and AC Outlets are off for 1 hour, the portable power station will turn off automatically to save energy.
- The timeout of the portable power station can be set or disabled on the DC Home app.

Maintenance

■ Cleaning

- Remove all the connections from the portable power station.
- Turn off the portable power station.
- Clear the leaves, debris, and dust from the fans of the portable power station.
- Clean the casing of the portable power station with a soft dry cloth.
- Keep the area around the portable power station clean and dry.
- Turn the portable power station back on.
- Reconnect the devices to the portable power station.

■ Storage





- Charge the portable power station to 50%.
- Remove all the connections from the portable power station.
- Turn off the portable power station.
- Handle the portable power station carefully to avoid sharp impacts or extreme pressure on the casing of the portable power station.
- Store the portable power station in a well ventilated, dry, clean area with temperatures between -4°F (-20°C) and 95°F (35°C) and humidity between 10% and 90%.
- For long term storage, discharge the portable power station to 30% and charge it to 50% every 6 months.
- Fully charge the portable power station when it is taken out of the storage.





WARNING





- DO NOT expose the portable power station to extreme temperatures above 131°F (55°C).
- DO NOT expose the portable power station to direct sunlight, moisture, or precipitation.
- Please keep the portable power station away from water, heat, dust, dirt, corrosives, and metal objects.
- Please ensure that no metal objects can fall on or around the portable power station.



Troubleshooting



- If the portable power station does not operate properly, refer to the table below for possible causes and corrective steps.
- If the corrective steps do not work, contact our customer service through renogy.com/contact-us/.

| Icons | Pattern | Possible Causes | Corrective Steps |
|--|------------|---|--|
| INPUT   | Slow Flash | AC Input Overvoltage/ Undervoltage | <ul style="list-style-type: none"> • Disconnect the AC Inlet from the wall outlet. • Measure the voltage of the wall outlet. Stop using the wall outlet if its voltage falls outside the specifications of the AC Inlet. • Connect the AC Inlet to the wall outlet with the appropriate voltage. Charging can be resumed. |
| Overload Protector Pop Up | | AC Input Overcurrent | <ul style="list-style-type: none"> • Disconnect the AC Inlet from the wall outlet. • Press down the Overload Protector to reset it. • Reconnect the AC Inlet to the wall outlet. • Contact us for help if the Overload Protector pops up again. |
| INPUT  | Slow Flash | DC Input Overvoltage/ Undervoltage | <ul style="list-style-type: none"> • Disconnect the charging source from the DC Input Port. • Check the voltage rating of the charging source. Stop using the charging source if its output voltage is rated lower than 10V or higher than 100V. • Connect the charging source with the appropriate voltage rating to the DC Input Port. Charging can be resumed. |
|   | Slow Flash | USB-A/ USB-A Fast Charge Output Overvoltage/ Undervoltage | <ul style="list-style-type: none"> • Disconnect the devices from the USB-A Ports and USB-A Fast Charge Port. • Short press the USB On/Off Button with the LCD Display lit up to release the protection. • Reconnect the device to the USB-A Ports and USB-A Fast Charge Port. • Contact us for help if the icons persist. |

| Icons | Pattern | Possible Causes | Corrective Steps |
|---|------------|---|--|
|  | Slow Flash | USB-A/ USB-A Fast Charge Output Overcurrent/Short Circuit | <ul style="list-style-type: none"> • Disconnect the devices from the USB-A Ports and USB-A Fast Charge Port. • Remove the short circuits if the USB-A Ports or USB-A Fast Charge Port are shorted. • Check the current ratings of the devices. Stop using the devices if they draw currents that exceed the specifications of the USB-A Ports or USB-A Fast Charge Port. • Short press the USB On/Off Button with the LCD Display lit up to release the protection. • Connect the devices with the appropriate current ratings to the USB-A Ports and USB-A Fast Charge Port. Power can be resumed. |
|  | Slow Flash | USB-C Output Overvoltage/ Undervoltage | <ul style="list-style-type: none"> • Disconnect the devices from the USB-C Ports. • Short press the USB On/Off Button with the LCD Display lit up to release the protection. • Reconnect the devices to the USB-C Ports. • Contact us for help if the icons persist. |
|  | Slow Flash | USB-C Output Overcurrent | <ul style="list-style-type: none"> • Disconnect the devices from the USB-C Ports. • Check the current ratings of the devices. Stop using the devices if they draw currents that exceed the specifications of the USB-C Ports. • Short press the USB On/Off Button with the LCD Display lit up to release the protection. • Connect the devices with the appropriate current ratings to the USB-C Ports. Power can be resumed. |
|  | Slow Flash | CIG Output Overvoltage/ Undervoltage | <ul style="list-style-type: none"> • Disconnect the device from the CIG Port. • Short press the CIG On/Off Button with the LCD Display lit up to release the protection. • Reconnect the device to the CIG Port. • Contact us for help if the icons persist. |

| Icons | Pattern | Possible Causes | Corrective Steps |
|---|------------|--------------------------------------|--|
|  | Slow Flash | CIG Output Overcurrent/Short Circuit | <ul style="list-style-type: none"> • Disconnect the device from the CIG Port. • Remove the short circuit if the CIG Port is shorted. • Check the current rating of the device. Stop using the device if it draws current that exceeds the specification of the CIG Port. • Short press the CIG On/Off Button with the LCD Display lit up to release the protection. • Connect the device with the appropriate current rating to the CIG Port. Power can be resumed. |
|  | Slow Flash | AC Output Overvoltage/Undervoltage | <ul style="list-style-type: none"> • Disconnect the devices from the AC Outlets. • Short press the AC On/Off Button with the LCD Display lit up to release the protection. • Reconnect the devices to the AC Outlets. • Contact us for help if the icons persist. |
|  | Slow Flash | AC Output Overload/Short Circuit | <ul style="list-style-type: none"> • Disconnect the devices from the AC Outlets. • Remove the short circuit if the AC Outlets are shorted. • Check the power ratings of the devices. Stop using the devices if their power ratings are higher than 1500W. • Short press the AC On/Off Button with the LCD Display lit up to release the protection. • Connect the devices with the appropriate power ratings to the AC Outlets. Power can be resumed. |
|  | Slow Flash | Inverter High Temperature | <ul style="list-style-type: none"> • Check if the fan inlet and outlet are blocked. • Cool down the portable power station to the room temperature. • Short press the AC On/Off Button with the LCD Display lit up to release the protection. Power can be resumed. |

| Icons | Pattern | Possible Causes | Corrective Steps |
|--|------------|--------------------------|---|
| OUTPUT  | Slow Flash | Total Output Overload | <ul style="list-style-type: none"> • Reallocate the output power to ensure that the total output power is under 2100W. • Short press the Power On/Off Button with the LCD Display lit up to release the protection. • Short press the USB On/Off Button, CIG On/Off Button, or AC On/Off Button to turn on the USB-A Ports, USB-A Fast Charge Port, and USB-C Ports, CIG Port, or AC Outlets again. Power can be resumed. |
|  | Slow Flash | Battery High Temperature | <ul style="list-style-type: none"> • Disconnect all the connections from the portable power station. • Check if the fan inlet and outlet are blocked. • Cool down the portable power station to the room temperature. • Reconnect the charging source(s) to the portable power station. Charging can be resumed. • Short press the USB On/Off Button, CIG On/Off Button, or AC On/Off Button to turn on the USB-A Ports, USB-A Fast Charge Port, and USB-C Ports, CIG Port, or AC Outlets again. Power can be resumed. |
|  | Slow Flash | Battery Low Temperature | <ul style="list-style-type: none"> • Warm up the portable power station. • Charging can be resumed automatically. • Short press the USB On/Off Button, CIG On/Off Button, or AC On/Off Button to turn on the USB-A Ports, USB-A Fast Charge Port, and USB-C Ports, CIG Port, or AC Outlets again. Power can be resumed. |

| Icons | Pattern | Possible Causes | Corrective Steps |
|---|------------|-------------------------------|--|
|  | Fast Flash | Single Phase Parallel Failure | <ul style="list-style-type: none"> • Disconnect the single phase parallel kit from the two RENOGY 1000 portable power stations. • Check the models of the portable power stations. Stop connecting them in parallel if they are of different models. • Check the output voltages of the AC Outlets. Stop connecting the two portable power stations in parallel if their AC Outlets have different output voltages. • Switch the AC Outlets of the two portable power stations to the same output frequency. • Fully charge the two portable power stations. • Reconnect the two portable power stations in parallel with the single phase parallel kit. |
|  | Fast Flash | Split Phase Parallel Failure | <ul style="list-style-type: none"> • Disconnect the split phase parallel kit from the two RENOGY 1000 portable power stations. • Check the models of the portable power stations. Stop connecting them in parallel if they are of different models. • Check the output voltages of the AC Outlets. Stop connecting the two portable power stations in parallel if their AC Outlets have different output voltages. • Switch the AC Outlets of the two portable power stations to the same output frequency. • Fully charge the two portable power stations. • Reconnect the two portable power stations in parallel with the single phase parallel kit. |

Specifications

| General | |
|-------------------------------|--|
| Dimension | 18.27 x 10.79 x 11.57 inch / 464 x 274 x 294 mm |
| Weight | 41.0 lbs / 18.6 kg |
| Charge Temperature | 32°F~104°F / 0°C~40°C (Recommended) 32°F~131°F / 0°C~55°C (Extreme) |
| Discharge Temperature | -4°F~104°F / -20°C~40°C (Recommended) -4°F~131°F / -20°C~55°C (Extreme) |
| Storage Temperature | -4°F~95°F / -20°C~35°C |
| Battery | |
| Type | Lithium Iron Phosphate |
| Capacity | 41.6V, 24000mAh / 998.4Wh |
| Cycle Life | 2000 Cycles (80% DOD, 80% EOL) |
| Input | |
| AC Input | 85V~120V (JP)/90V~140V (US, CA)/200V~240V (EU, UK, AU, KR, CN) ~ 45Hz~55Hz/57Hz~65Hz, 998W Max |
| DC Input | 10V~100V --- 10A, 400W Max |
| Output | |
| USB-A Output (x2) | 5V --- 2.4A, 12W Max |
| USB-A Fast Charge Output (x1) | 5V --- 3A, 9V --- 2A, 12V --- 1.5A, 18W Max |
| USB-C Output (x1) | 5V --- 3A, 9V --- 3A, 12V --- 3A, 15V --- 3A, 20V --- 5A, 100W Max |
| CIG Output (x1) | 13.6V --- 10A, 136W Max |
| AC Output (x3/x6) | 100V (JP)/120V (US, CA)/220V~240V (EU, UK, AU, KR, CN) ~ 50Hz/60Hz, 1500W Rated, 3000W Surge |
| Total Output | 2100W Max |

FCC STATEMENT

This device complies with Part 15 of the FCC Rules. Operation is subject to the following two conditions:

- (1) This device may not cause harmful interference, and
- (2) This device must accept any interference received, including interference that may cause undesired operation.

This equipment has been tested and found to comply with the limits for a Class A digital device, pursuant to Part 15 of the FCC Rules. These limits are designed to provide reasonable protection against harmful interference in a residential installation. This equipment generates uses and can radiate radio frequency energy and, if not installed and used in accordance with the instructions, may cause harmful interference to radio communications. However, there is no guarantee that interference will not occur in a particular installation. If this equipment does cause harmful interference to radio or television reception, which can be determined by turning the equipment off and on, the user is encouraged to try to correct the interference by one or more of the following measures:

- (1) Orient or relocate the receiving antenna.
- (2) Increase the separation between the equipment and receiver.
- (3) Connect the equipment into an outlet on a circuit different from that to which the receiver is connected.
- (4) Consult the dealer or an experienced radio/TV technician for help.

FCC RADIATION EXPOSURE STATEMENT

This equipment complies with FCC radiation exposure limits set forth for an uncontrolled environment. This equipment should be installed and operated with minimum distance 20cm between the radiator & your body.



| | |
|----|-----|
| EC | REP |
|----|-----|

eVatmaster Consulting GmbH
Battinastr. 30
60325 Frankfurt am Main, Germany
contact@evatmaster.com

| | |
|----|-----|
| UK | REP |
|----|-----|

EVATOST CONSULTING LTD
Suite 11, First Floor, Moy Road Business
Centre, Taffs Well, Cardiff, Wales, CF15 7QR
contact@evatmaster.com

Renogy reserves the right to change the contents of this manual without notice.

US |  5050 S Archibald Ave, Ontario, CA 91762
 909-287-7111
 www.renogy.com

CN |  苏州高新区科技城培源路1号5号楼-4
 400-6636-695
 www.renogy.cn

JP |  www.renogy.jp

CA |  ca.renogy.com

AU |  au.renogy.com

UK |  uk.renogy.com

DE |  de.renogy.com