

We know you care.

Choosing to go solar is a huge step toward being sustainable. Go green with Renogy without compromising on a comfortable lifestyle.

# GO SOLAR

 **RENOGY**<sup>®</sup>

**Solar 400W 2.56kWh Extension  
Solution**

**QUICK GUIDE**

VERSION A0



**Find Your Energy Freedom**



## Before Getting Started

The quick guide provides important installation instructions for Renogy Solar 400W 2.56kWh Extension Solution. For detailed operation and maintenance tips, refer to the user manual of the specific product at [renogy.com/support/downloads](https://renogy.com/support/downloads).

Read the quick guide carefully before installation. Failure to observe the instructions or precautions in the quick guide can result in electrical shock, serious injury, or death, or can damage the included products, potentially rendering them inoperable.

- Renogy ensures the accuracy, sufficiency, and the applicability of information in the quick guide or user manual at the time of printing due to continual product improvements that may occur.
- Renogy assumes no responsibility or liability for personal and property losses, whether directly and indirectly, caused by the user's failure to install and use the product in compliance with the quick guide.
- Renogy is not responsible or liable for any failure, damage, or injury resulting from repair attempts by unqualified personnel, improper installation, or inappropriate operation.
- The illustrations in the quick guide are for demonstration purposes only. Details may appear slightly different depending on product revision and market region.
- Renogy reserves the right to change the information in the quick guide without notice. For the latest quick guide, visit [renogy.com/support/downloads](https://renogy.com/support/downloads).

## Disclaimer

Renogy Solar 400W 2.56kWh Extension Solution Quick Guide © 2023 Renogy. All rights reserved.

**RENOGY** and **RENOGY** are registered trademarks of Renogy.

- All information in the quick guide is subject to copyright and other intellectual property rights of Renogy and its licensors. The quick guide may not be modified, reproduced, or copied, in whole or in part, without the prior written permissions of Renogy and its licensors.
- The registered trademarks in the quick guide are the property of Renogy. The unauthorized use of the trademarks is strictly prohibited.

## Statutes and Regulations

The mechanical and electrical installation of solar panels should refer to the appropriate regulations, including electrical code, building code and electrical connection requirements. These regulations vary depending on the location of the installation, e.g., building rooftop installation, vehicle-mounted applications, etc. Requirements may also vary with the voltage of the installation system, the nature of the current (DC or AC). Please contact your local authority for specific terms.

## DC Home App



DC Home App



# 1. System Wiring

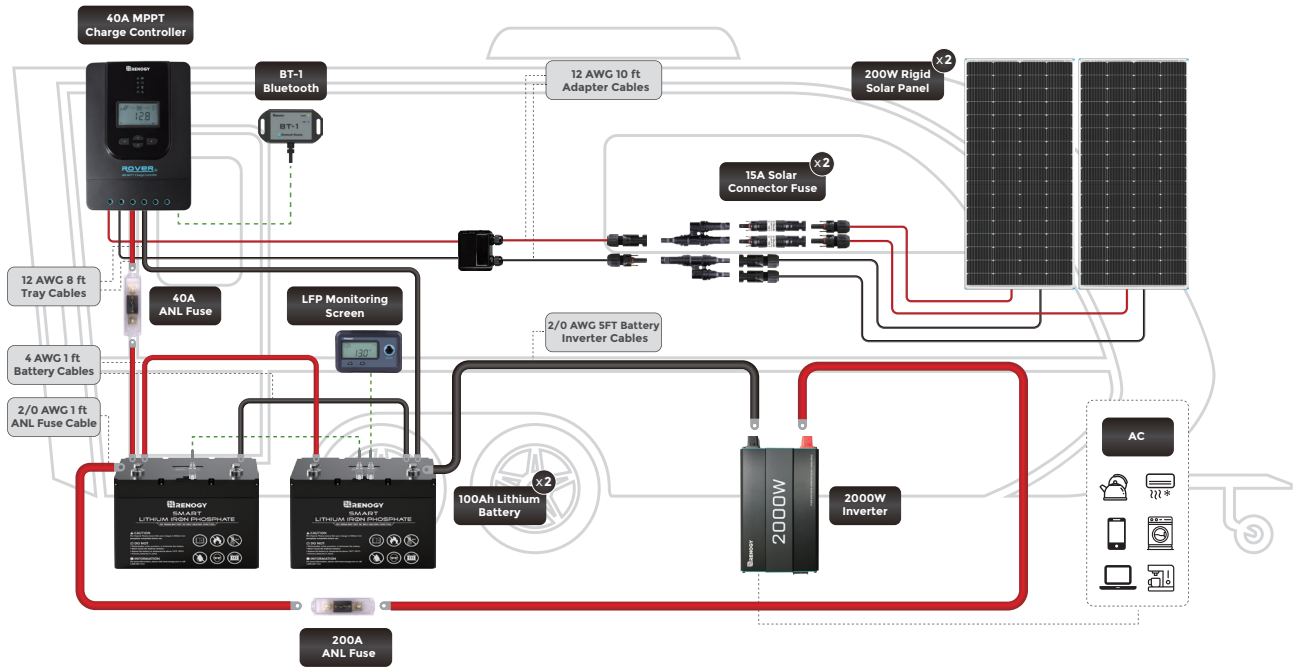

## 2. Get to Know Renogy Solar 400W 2.56kWh Extension Solution

### ■ Battery

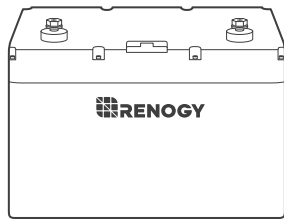

100Ah Lithium Battery x 2

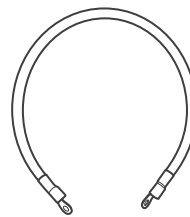

4 AWG 1 ft Battery Interconnect Cable x 2

### ■ Charge Controller

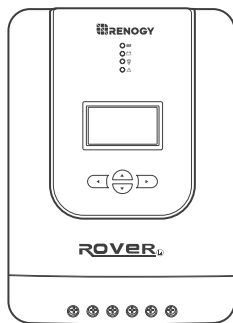

40A MPPT Charge Controller x 1

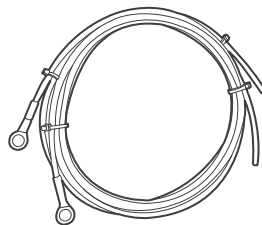

12 AWG 8 ft Tray Cables  
(Charge Controller to Battery) x 1

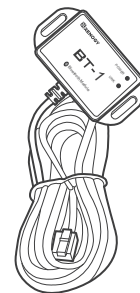

Renogy BT-1 Bluetooth Module  
(New Version) x 1

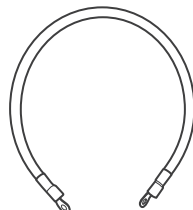

10 AWG 2 ft ANL Fuse Cable x 1

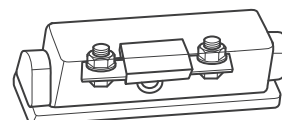

40A ANL Fuse x 1

## ■ Solar Panels

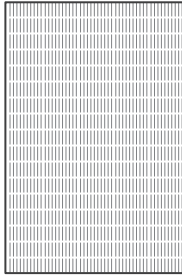

200W Rigid Solar Panel × 2

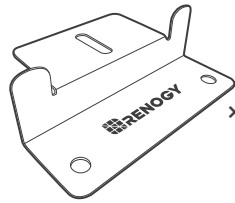

× 4

Solar Panel Mounting Z Bracket × 2

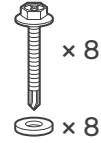

× 8



× 8



× 4



× 4



× 4



× 8

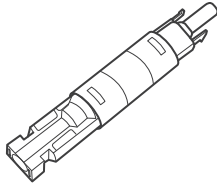

15A Solar Connector Fuse × 2

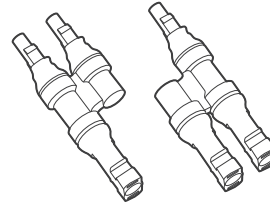

Solar Branch Connector (MMF + FFM Pair) × 1

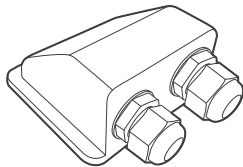

Solar Entry Gland × 1



12 AWG 10 ft Adapter Kit  
(Solar Panel to Charge Controller) × 1

## ■ Inverter

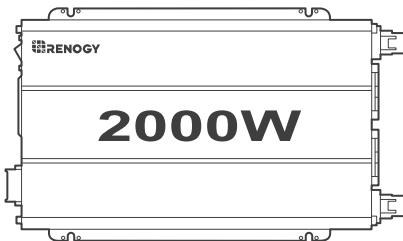

2000W Inverter × 1

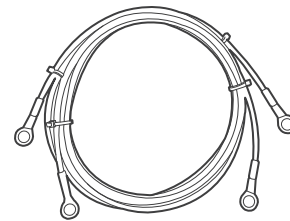

2/0 AWG 5 ft Battery Inverter Cables  
(Inverter to Battery) × 1

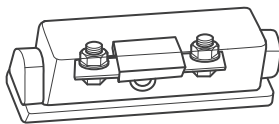

200A ANL Fuse × 1

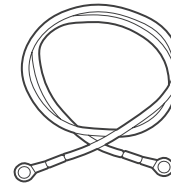

2/0 AWG 1 ft ANL Fuse Cable × 1

## ■ Battery Monitor

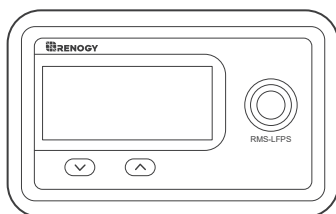

Monitoring Screen for Smart Lithium Battery × 1

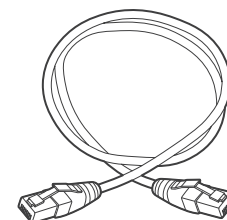

RJ45 Communication Cable × 1

### 3. Required Tools & Accessories



Phillips  
Screwdriver (#2)

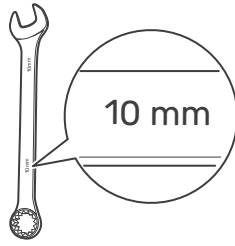

Wrench  
(7/16 in)

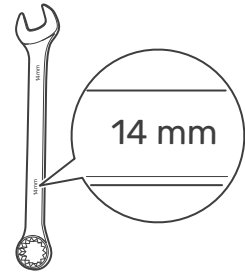

Wrench  
(9/16 in)

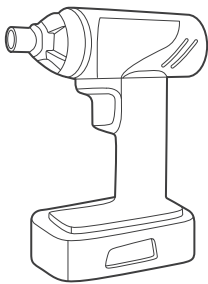

Impact Drill



Phillips Driver Bit (#2)

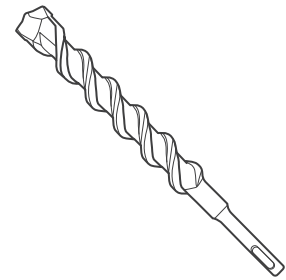

Masonry Drill Bit  
(21/64 in)

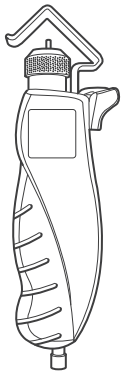

Wire Stripper

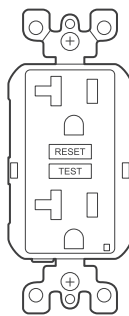

Ground Fault Circuit  
Interrupter (GFCI) (≥20A)

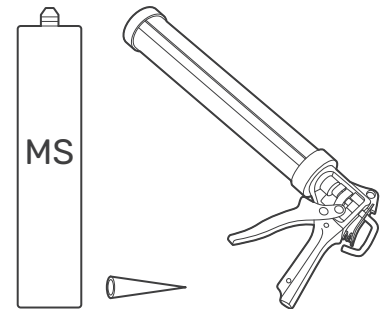

MS Adhesive and  
MS Applicator Gun

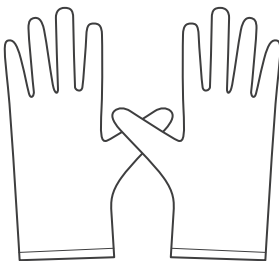

Insulating Gloves

## 4. How to Install the Solar Panel Mounting Z Bracket

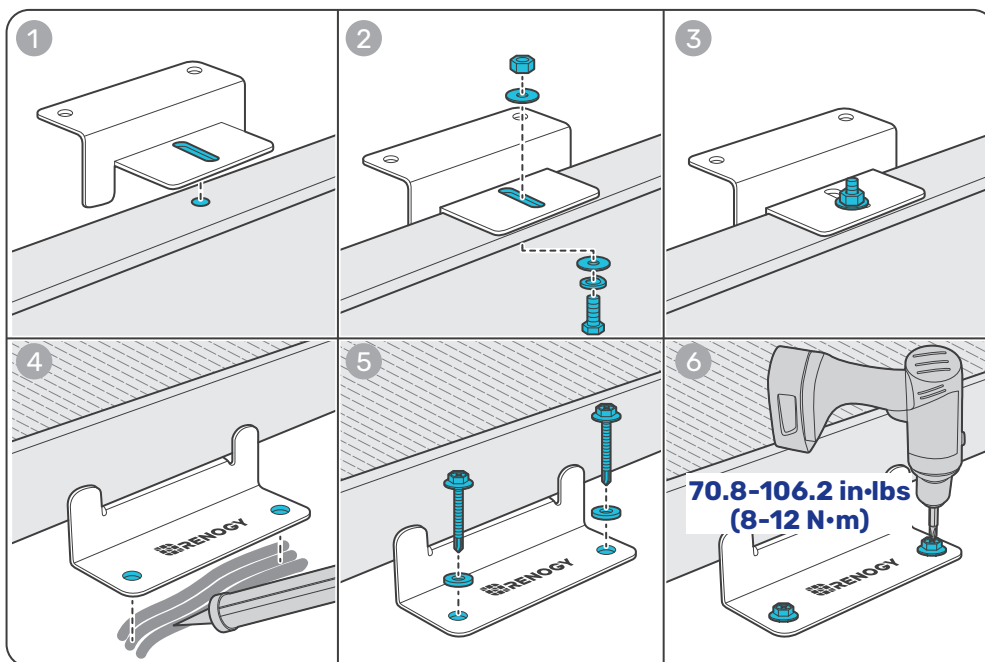

Solar Panel    Solar Panel

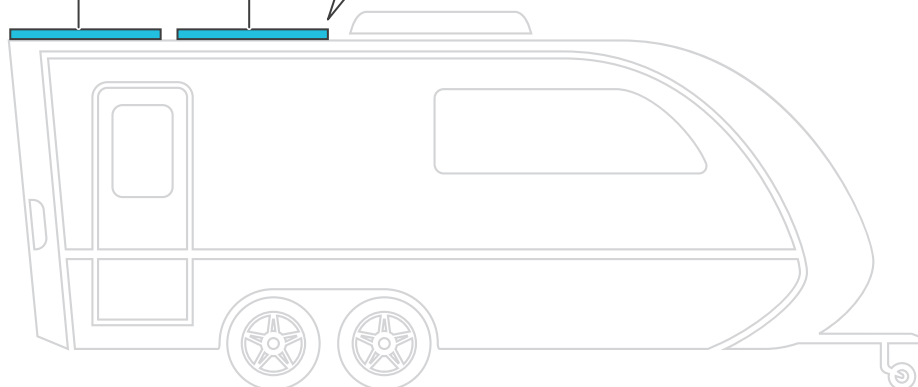

## 5. How to Install the Solar Entry Gland

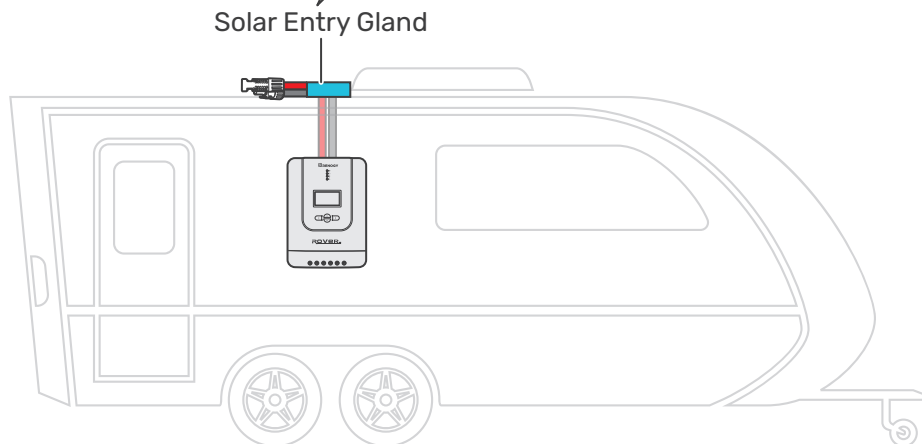
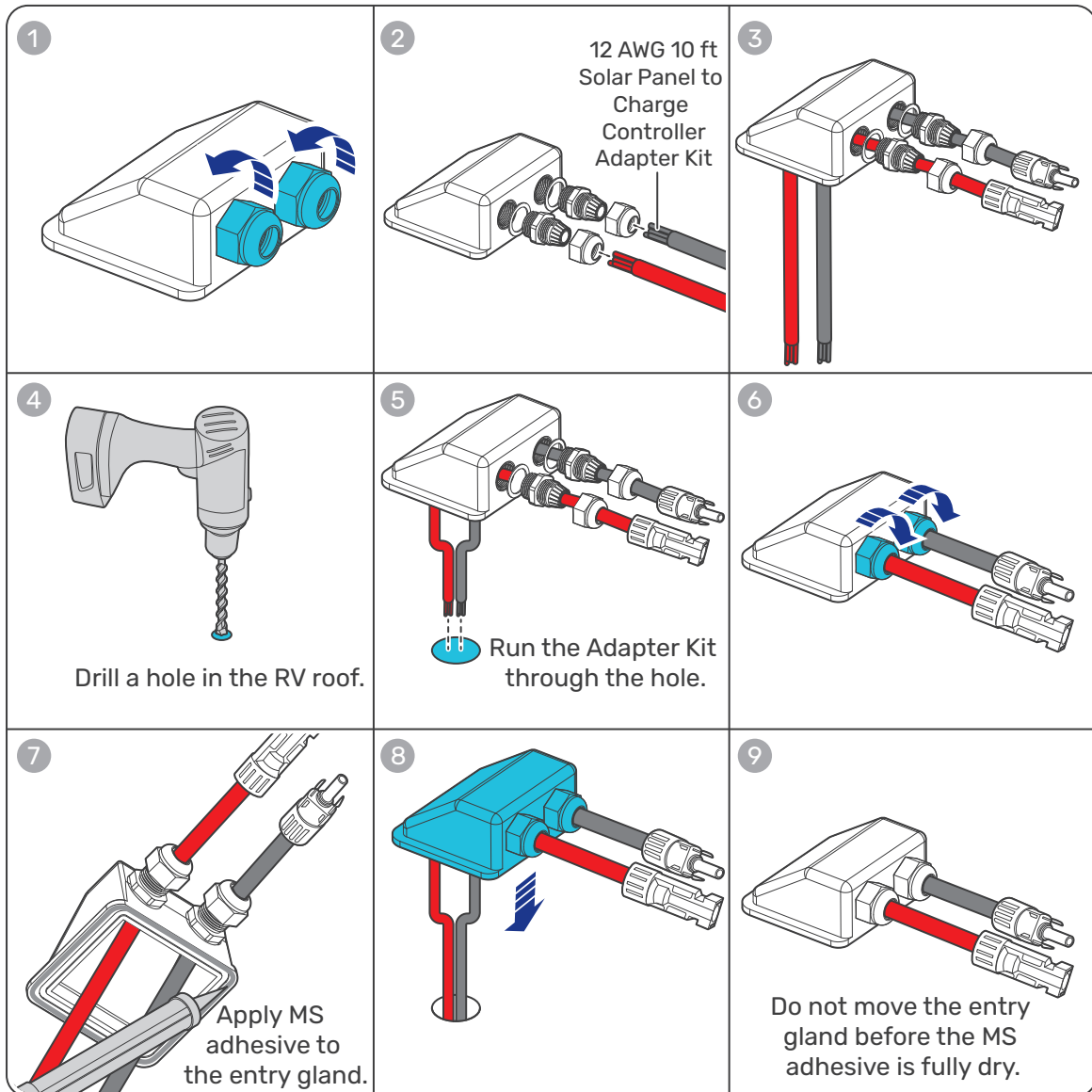

# Step 1. Connect the Batteries in Parallel

## Step-1 Ensure that all batteries are in shelf mode.

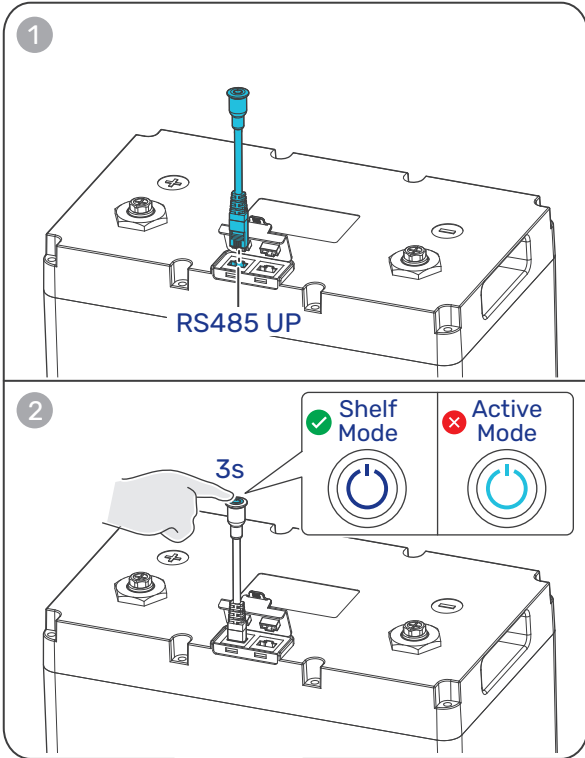

## Step-2 Connect the batteries in parallel.

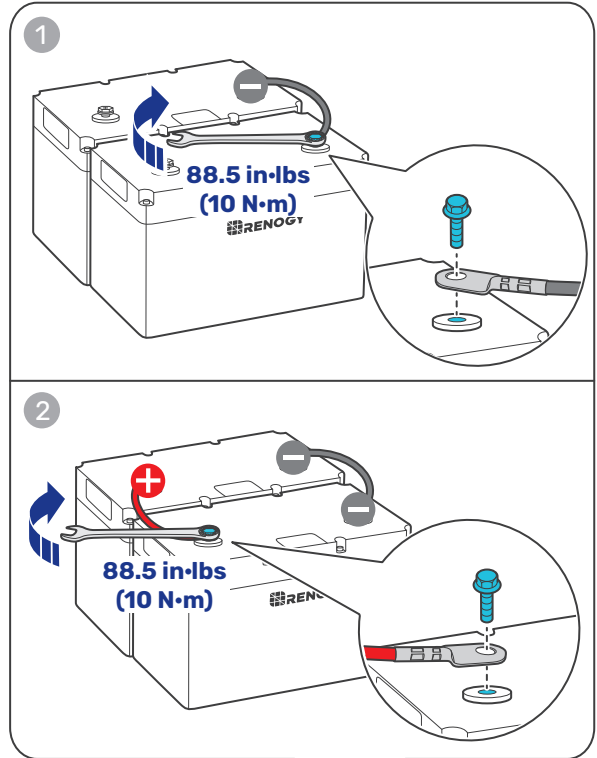

4 AWG 1 ft Battery Interconnect Cables

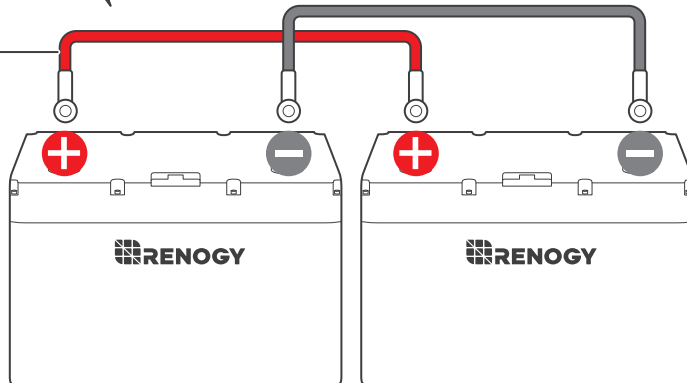

100Ah Lithium Batteries



## Step 2. Connect the Charge Controller to the Batteries

**Note:** Connect the batteries first and then the solar panels to avoid irreversible damage to the charge controller.

### STEP-1 Install the cables on the charge controller.

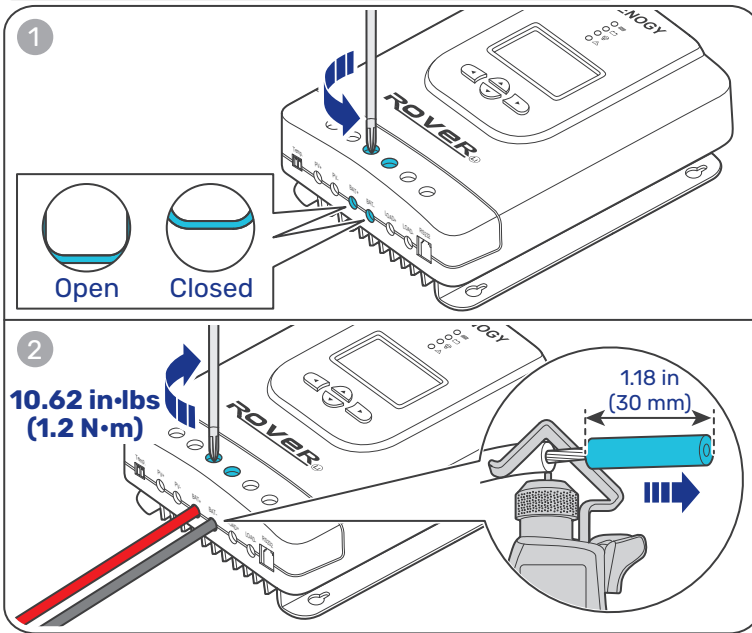

40A MPPT Charge Controller

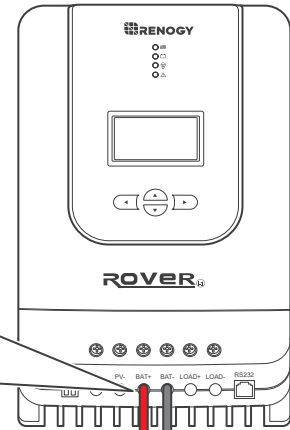

12 AWG 8 ft Tray Cables

### STEP-2 Install a 40A ANL fuse

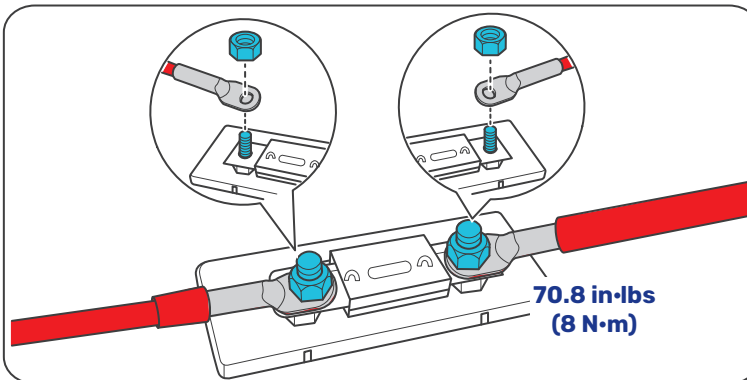

40A ANL Fuse

### STEP-3 Install the cables on the batteries.

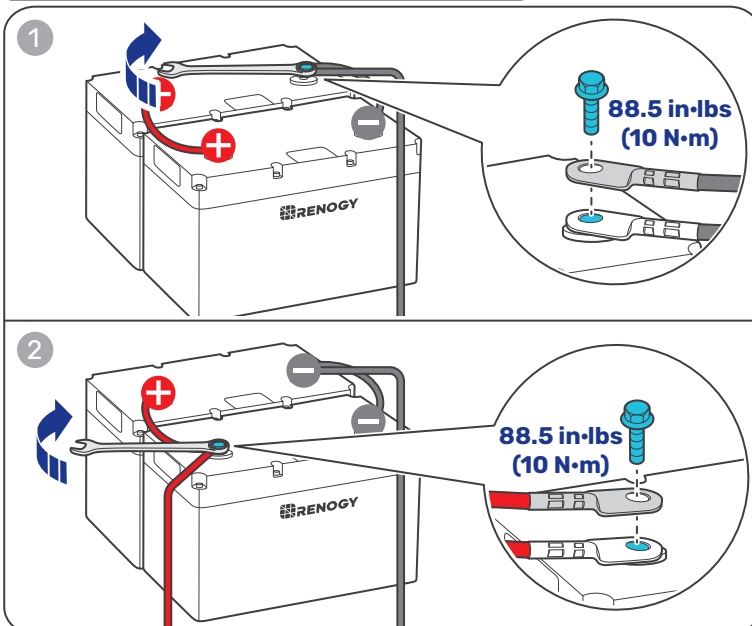

10 AWG 2 ft ANL Fuse Cable

100Ah Lithium Batteries

# Step 3. Connect the Bluetooth Module to the Charge Controller

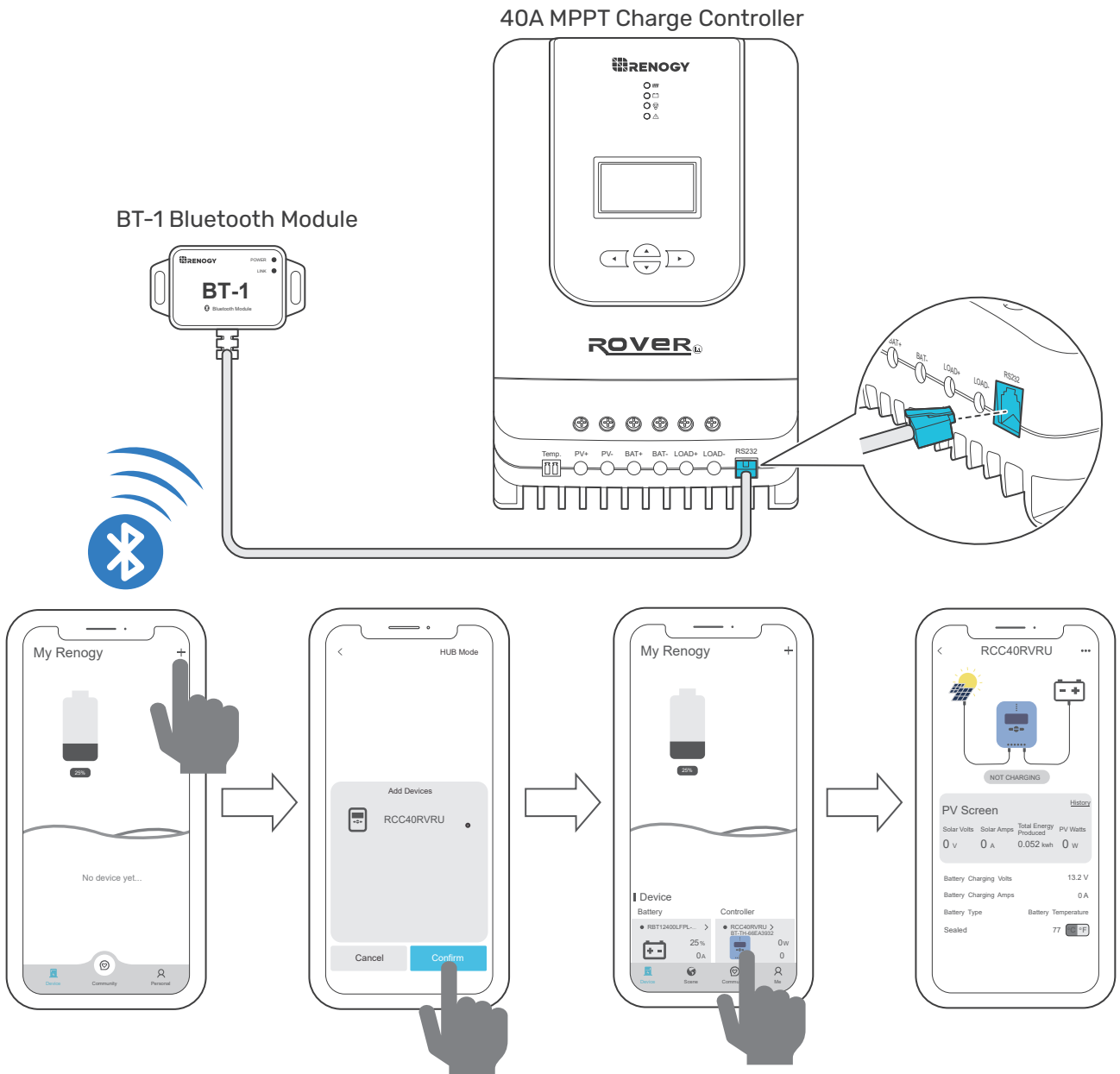

## Step 4. Connect the Solar Panels to the Charge Controller

**Note:** Connect the batteries first and then the solar panels to avoid irreversible damage to the charge controller.

### STEP-1 Install 15A Solar Connector Fuses

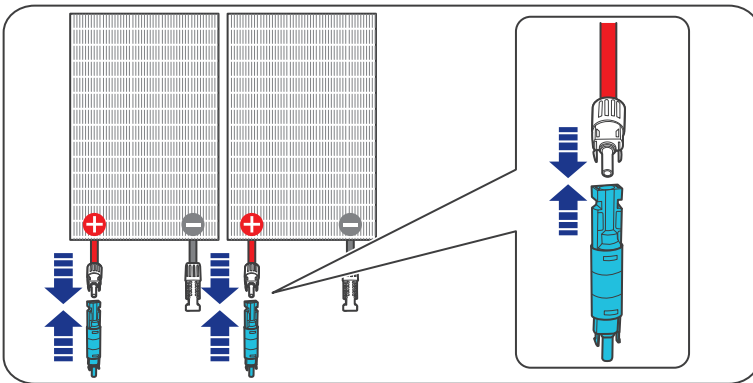

### STEP-2 Connect the solar panels in parallel.

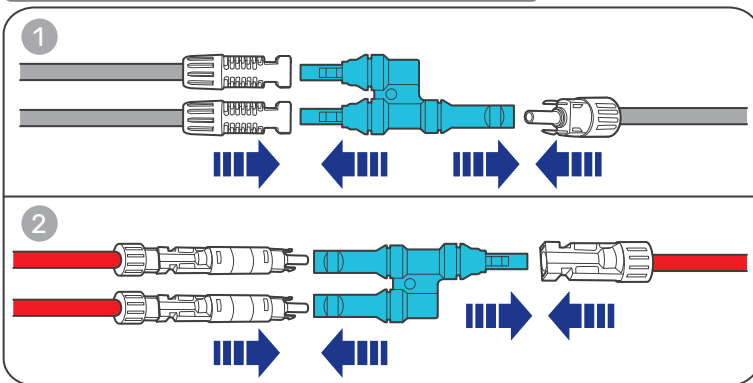

### STEP-3 Install the adapter kit on the charge controller.

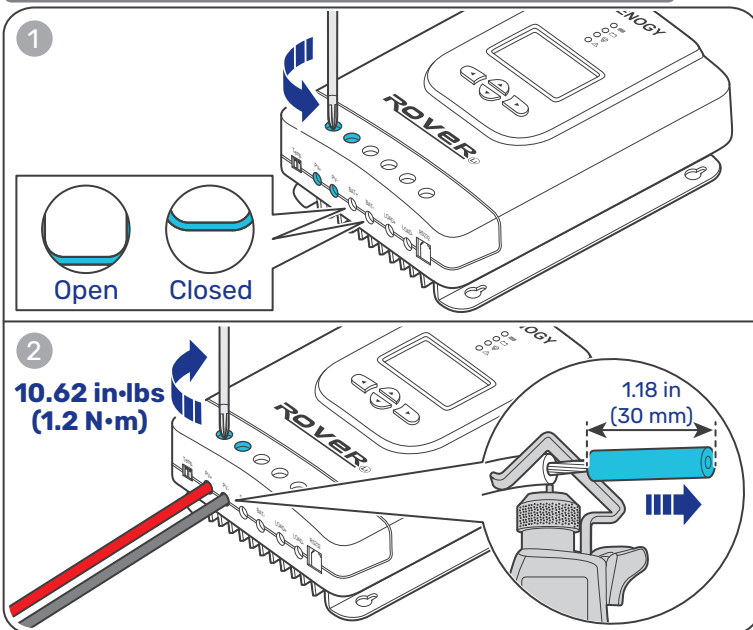

### 200W Rigid Solar Panels

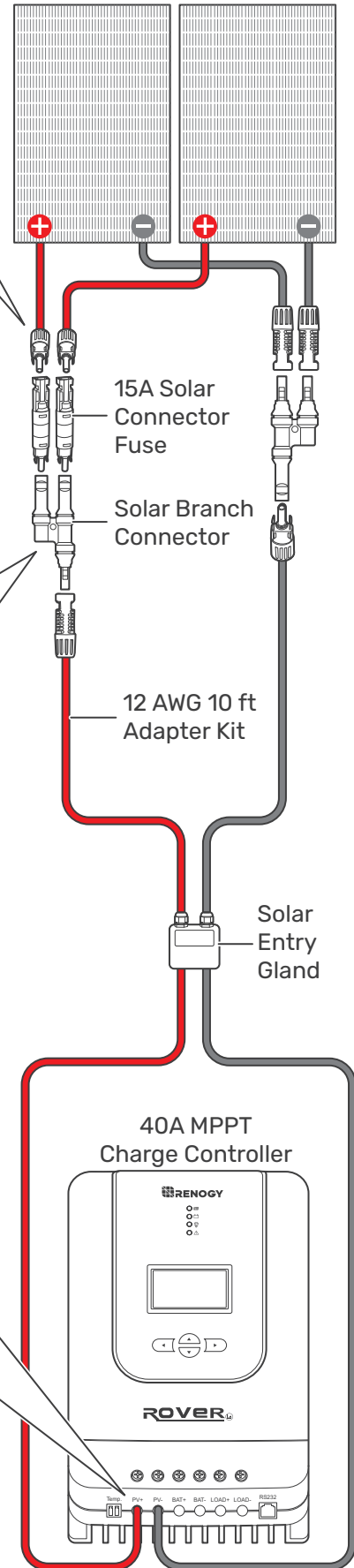

# Step 5. Install the Inverter and Loads

## STEP-1 Install the cables on the batteries.

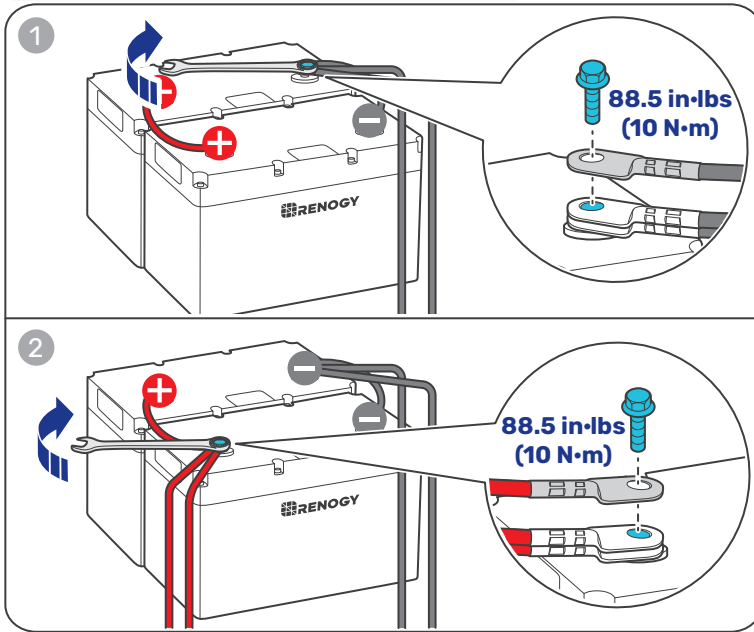

## STEP-2 Install a 200A ANL fuse

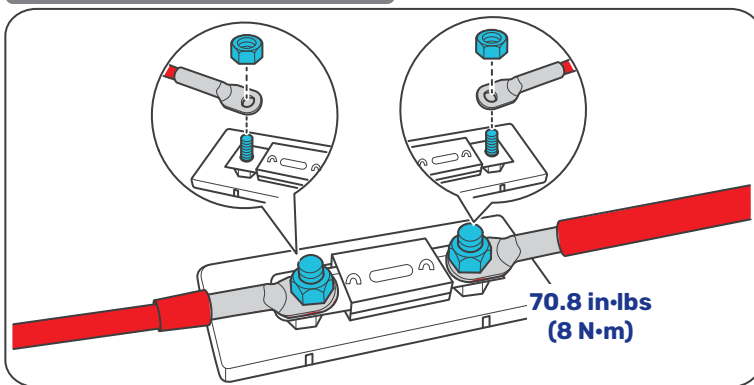

## STEP-3 Install the cables on the inverter.

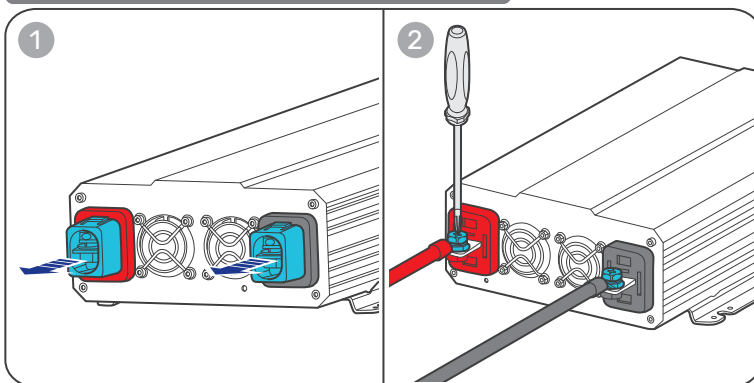

## STEP-4 Install the GFCI on the inverter.

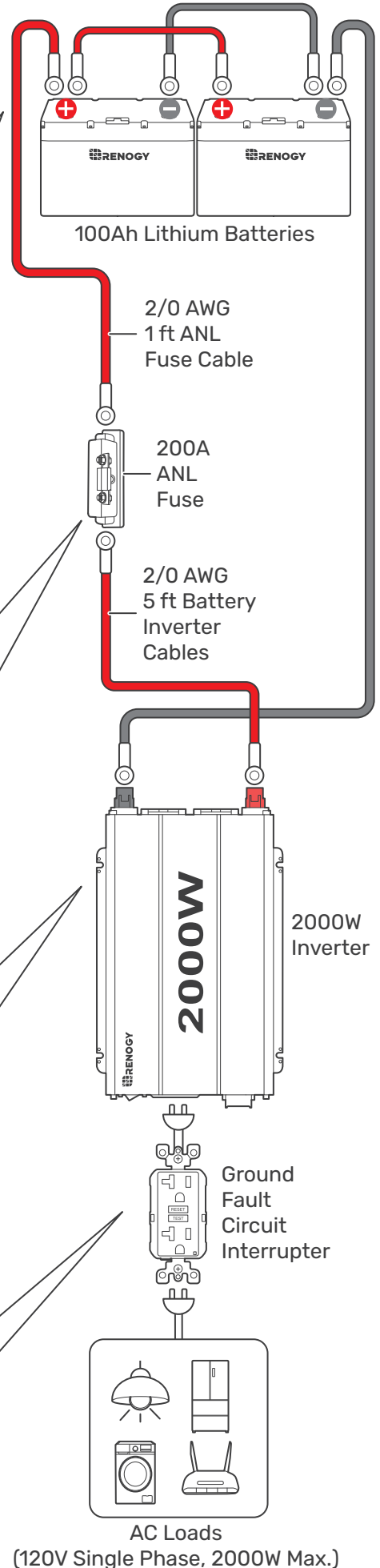
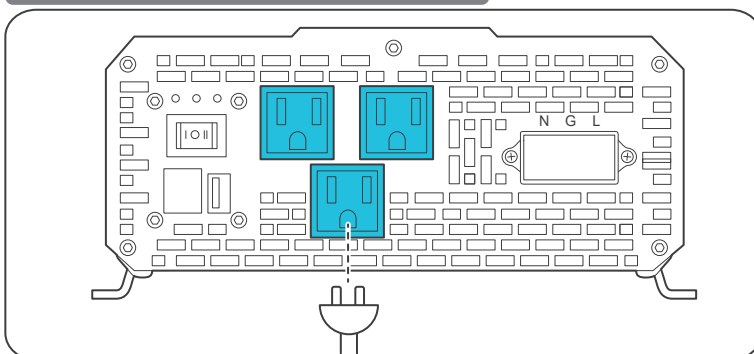

# Step 6. Communication and Monitoring Wiring

Step-1 Ensure that all batteries are in active mode.

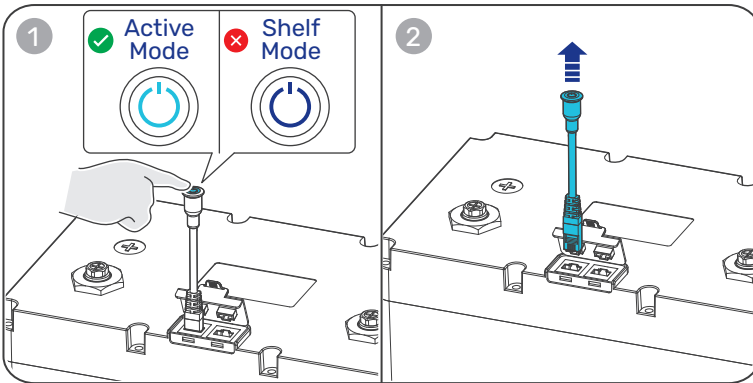

Step-2 Install the monitoring screen on the first battery.

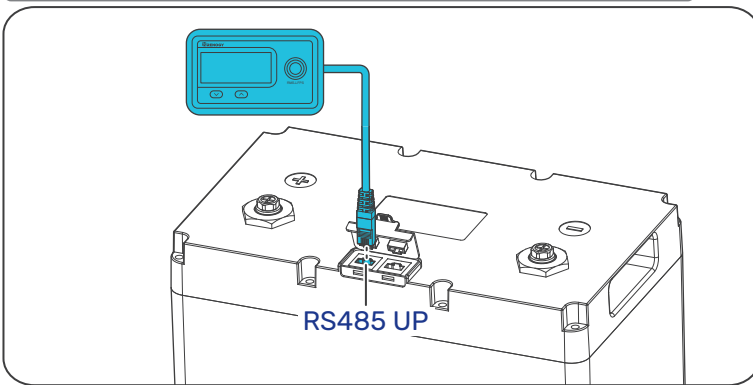

Step-3 Install the communication cable on the batteries.

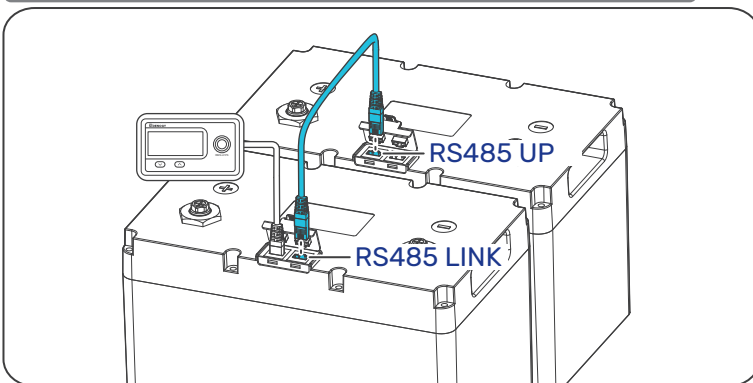

Monitoring Screen for Smart Lithium Battery

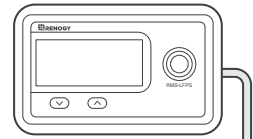

RJ45 Communication Cable

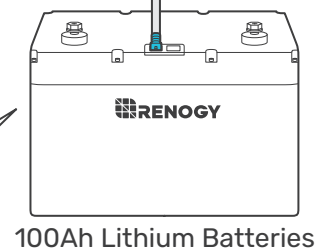

100Ah Lithium Batteries

# Renogy Support

To discuss inaccuracies or omissions in this quick guide or user manual, visit or contact us at:

 | [renogy.com/support/downloads](https://renogy.com/support/downloads)

 [contentservice@renogy.com](mailto:contentservice@renogy.com)

To explore more possibilities of solar systems, visit Renogy Learning Center at:

 | [renogy.com/learning-center](https://renogy.com/learning-center)

For technical questions about your product in the U.S., contact the Renogy technical support team through:

 | [renogy.com/contact-us](https://renogy.com/contact-us)

 1(909)2877111

For technical support outside the U.S., visit the local website below:

**Canada** |  | [ca.renogy.com](https://ca.renogy.com)

**China** |  | [www.renogy.cn](https://www.renogy.cn)

**Australia** |  | [au.renogy.com](https://au.renogy.com)

**Japan** |  | [renogy.jp](https://renogy.jp)

**South Korea** |  | [kr.renogy.com](https://kr.renogy.com)

**Germany** |  | [de.renogy.com](https://de.renogy.com)

**United Kingdom** |  | [uk.renogy.com](https://uk.renogy.com)

**Other Europe** |  | [eu.renogy.com](https://eu.renogy.com)

# Safety Information

## General

- Wear proper protective equipment and use insulated tools during installation and operation. Do not wear jewelry or other metal objects when working on or around the devices.
- Keep the devices out of the reach of children.
- Do not dispose of the devices as household waste. Comply with local, state, and federal laws and regulations and use recycling channels as required.
- In case of fire, put out the fire with a FM-200 or CO<sub>2</sub> fire extinguisher.
- Installing the devices improperly on a boat may cause damage to components of the boat. Have the devices installed by a qualified electrician.
- Do not expose the devices to flammable or harsh chemicals or vapors.
- Clean the devices regularly.
- Do not puncture, drop, crush, penetrate, shake, strike, or step on the devices.
- Do not open, disassemble, repair, tamper with, or modify the devices.
- Connect the negative prior to the positive terminal when connecting any device.

## Battery Safety

- Do not use batteries if there is any damage.
- Do not touch the exposed electrolyte or powder if the battery is damaged.
- Risk of explosion! Never install the charge controller and inverter in a sealed enclosure with flooded batteries! Do not install the charge controller, and inverter in a confined area where battery gases can accumulate.
- Prior to installing the devices, ensure all battery groups are installed properly.

## Charge Controller, and Inverter Safety

- Install the devices indoors on a vertical surface - protected from direct sunlight, high temperatures, and water. Make sure there is good ventilation.
- Keep the devices away from heating equipment.
- Do not insert foreign objects into the devices.
- Confirm the polarities of the devices before connection. A reverse polarity contact can result in damage to the devices, thus voiding the warranty.
- Do not touch the connector contacts while the devices are in operation.
- Disconnect all connectors from the devices before maintenance or cleaning.
- Ensure the inverter is firmly grounded to a building, vehicle, or earth grounded. Keep the inverter away from EMI receptors such as TVs, radios, and other audio/visual electronics to prevent damage / interference to the equipment.

## Solar Panel Safety

- Do not install the solar panel on a surface constructed from combustible material.
- Do not expose the solar panel to direct flame or heat sources.
- Keep the solar panel away from explosives and corrosive substances.
- Do not step, walk, stand, or jump on the solar panel. Localized heavy loads may cause damage to the solar cells, which will ultimately compromise the performance of the solar panel.
- Do not bend the solar panel. Bending the solar panel will cause damage to the cells and affect panel performance.
- Do not immerse the solar panel in water.



## Renogy Empowered

Renogy aims to empower people around the world through education and distribution of DIY-friendly renewable energy solutions.

We intend to be a driving force for sustainable living and energy independence.

In support of this effort, our range of solar products makes it possible for you to minimize your carbon footprint by reducing the need for grid power.



## Live Sustainably with Renogy

Did you know? In a given month, a 1kW solar energy system will...



Save 170 pounds of coal from being burned



Save 300 pounds of CO<sub>2</sub> from being released into the atmosphere



Save 105 gallons of water from being consumed



## Renogy Power PLUS

Renogy Power Plus allows you to stay in the loop with upcoming solar energy innovations, share your experiences with your solar energy journey, and connect with like-minded people who are changing the world in the Renogy Power Plus community.



@Renogy Solar



@renogyofficial



@Renogy

Renogy reserves the right to change the contents of this quick guide without notice.